

IMPORTANT SAFETY INFORMATION

VOLUNTARY RECALL

PERI LIFTING HEAD REVISIONS 0, A AND B

November 22, 2024

PRODUCT TYPE

PERI Lifting Head STH / Art.-No. 107709

MODEL

Revision 0, Revision a, Revision b

PRODUCTION YEAR

2003 - 2006

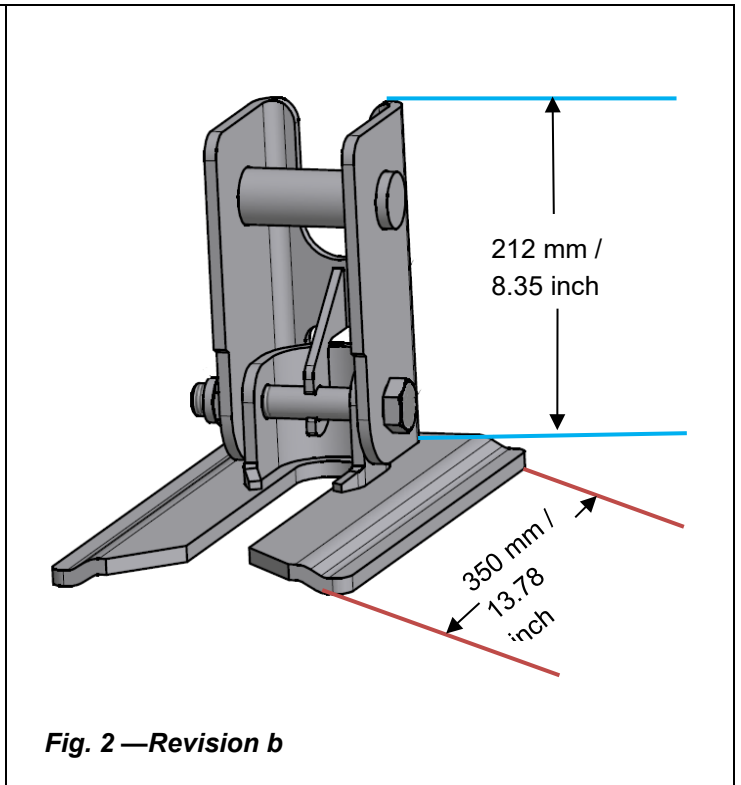
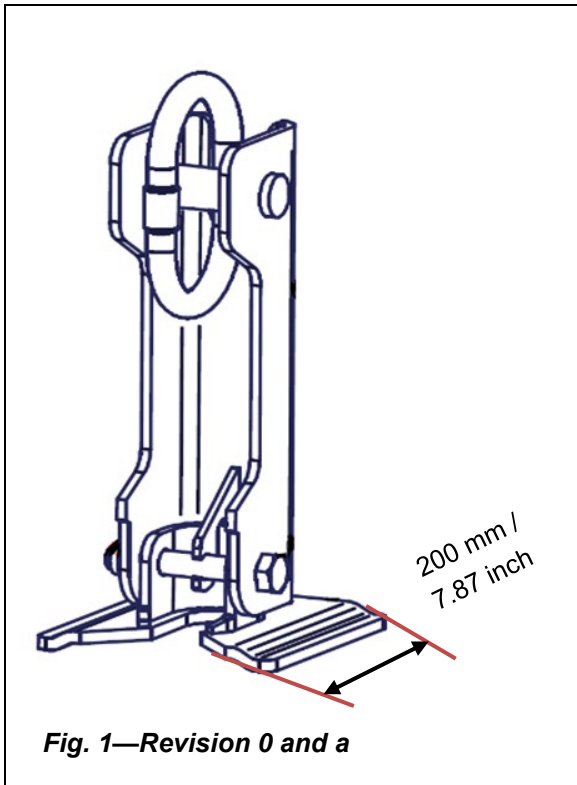

1. WHY YOU ARE RECEIVING THIS NOTICE

PERI has identified potential safety issues involving PERI LIFTING HEAD STH (“LIFTING HEAD”), specifically **Revisions 0, a and b** sold between 2003 and 2006 (the “**AFFECTED LIFTING HEADS**” (pictured in Figs. 1, 2 above)). PERI has determined that the **AFFECTED LIFTING HEADS** are still being used on construction sites in North America and that there may be potential misuse of the **AFFECTED LIFTING HEADS** by users contrary to PERI’s instruction manuals.

PERI has identified you as a potential customer, owner or user of LIFTING HEADS, including the AFFECTED LIFTING HEADS. It is important that you immediately read and comply with this safety notice. If you have provided LIFTING HEADS to other users, it is critical that you immediately provide this notice to them.

2. NATURE OF THE ISSUE & SAFETY RISKS



PERI has learned that at least one user improperly modified a LIFTING HEAD by combining the bottom piece of an older **AFFECTED LIFTING HEAD** with the top piece of a later version of a LIFTING HEAD. Modifying the **AFFECTED LIFTING HEADS** (or any LIFTING HEAD version) by combining and using components from different generations of LIFTING HEADS or other hardware may impact the performance and safety of the LIFTING HEAD. Modification of any LIFTING HEADS is expressly contrary to PERI’s instruction manuals. **Users must not mix and match parts from different generations of LIFTING HEADS and must follow all instructions for use.** It is critical that only PERI factory designed and approved LIFTING HEADS be used and that there is always a proper connection of the LIFTING HEAD to the SKYTABLE before movement. Failure to follow all instructions for use or the failure to use factory designed and approved LIFTING HEADS free of excessive wear and tear or damage could cause the LIFTING HEAD to detach from the SKYTABLE causing the SKYTABLE to fall. **THIS COULD RESULT IN SEVERE PERSONAL INJURY, DEATH OR PROPERTY DAMAGE.**

BECAUSE OF THIS POTENTIAL FOR MISUSE AND THE AVAILABILITY OF LATER GENERATIONS, PERI IS VOLUNTARILY RECALLING ALL AFFECTED LIFTING HEADS.

3. INSTRUCTIONS

IDENTIFICATION AFFECTED LIFTING HEADS

Inspect your LIFTING HEADS to determine whether they are Revision 0, a or b. If you possess **AFFECTED LIFTING HEADS**, immediately withdraw them from service and discontinue any further use regardless of any visible signs of physical wear and tear. If you are unable to determine whether you possess **AFFECTED LIFTING HEADS**, please contact the PERI representative designated below. If your LIFTING HEAD is Revisions c or later generations, you may continue to use it pursuant to the applicable instruction manuals and the Safety Information and Warnings below.

SCRAP/DISCONTINUE USE OF AFFECTED LIFTING HEADS

All **AFFECTED LIFTING HEADS** must be taken out of service immediately and scrapped to prevent accidental use. If you arrange for the scrapping yourself, PERI recommends that you keep a record of scrapping. If the **AFFECTED LIFTING HEAD** cannot be scrapped immediately, they should be clearly marked with paint to ensure they are not accidentally used. Alternatively, you may return the **AFFECTED LIFTING HEAD** to PERI for professional scrapping free of charge.

Customers who wish to replace the AFFECTED LIFTING HEADS should contact their PERI representative to discuss the procurement of a new LIFTING HEAD. PERI will provide a credit to purchase a new, replacement LIFTING HEAD.

MODIFIED LIFTING HEADS



ONLY AFFECTED LIFTING HEADS ARE SUBJECT OF THIS VOLUNTARY RECALL. HOWEVER, ANY OTHER GENERATIONS OF LIFTING HEADS THAT HAVE BEEN MODIFIED ARE ALSO REQUIRED TO BE IMMEDIATELY REMOVED FROM SERVICE. CONTINUED USE COULD RESULT IN SEVERE PERSONAL INJURY, DEATH OR PROPERTY DAMAGE. IF YOU ARE UNABLE TO DETERMINE WHETHER A LIFTING HEAD HAS BEEN MODIFIED, IMMEDIATELY CONTACT PERI PER THE BELOW INFORMATION.

SAFETY INFORMATION AND WARNINGS REGARDING ALL LIFTING HEADS



INSPECTION. Excessive wear and tear or damage (or modification) of LIFTING HEADS may increase the risk of use and compromise their safety. Excessive wear and damage to the safety flanges of LIFTING HEADS may allow the spigot to be improperly inserted and secured into the LIFTING HEAD. If improper insertion and securing of the spigot occurs, this could cause the LIFTING HEAD to become detached from the SKYTABLE during lifting. Pursuant to the instruction manual, it is critical that all users ensure there is a proper and safe connection of the LIFTING HEAD to the SKYTABLE before the lifting process. **FAILURE TO INSPECT LIFTING HEADS BEFORE EACH USE OR TO FOLLOW THE INSTRUCTIONS FOR USE COULD RESULT IN SEVERE PERSONAL INJURY, DEATH OR PROPERTY DAMAGE.**

If you need assistance with identifying the LIFTING HEAD version or need additional information on inspection, please contact the PERI representative identified below.

CONTACT INFORMATION

Please contact your PERI representative:

PERI is committed to the highest levels of product quality and safety. PERI apologizes for any inconvenience this notice may cause your business. PERI values its customers and will work diligently with you to best minimize any inconvenience.