

MULTIPROP System

Instructions for Assembly and Use – Standard Configuration – Issue 01/2020

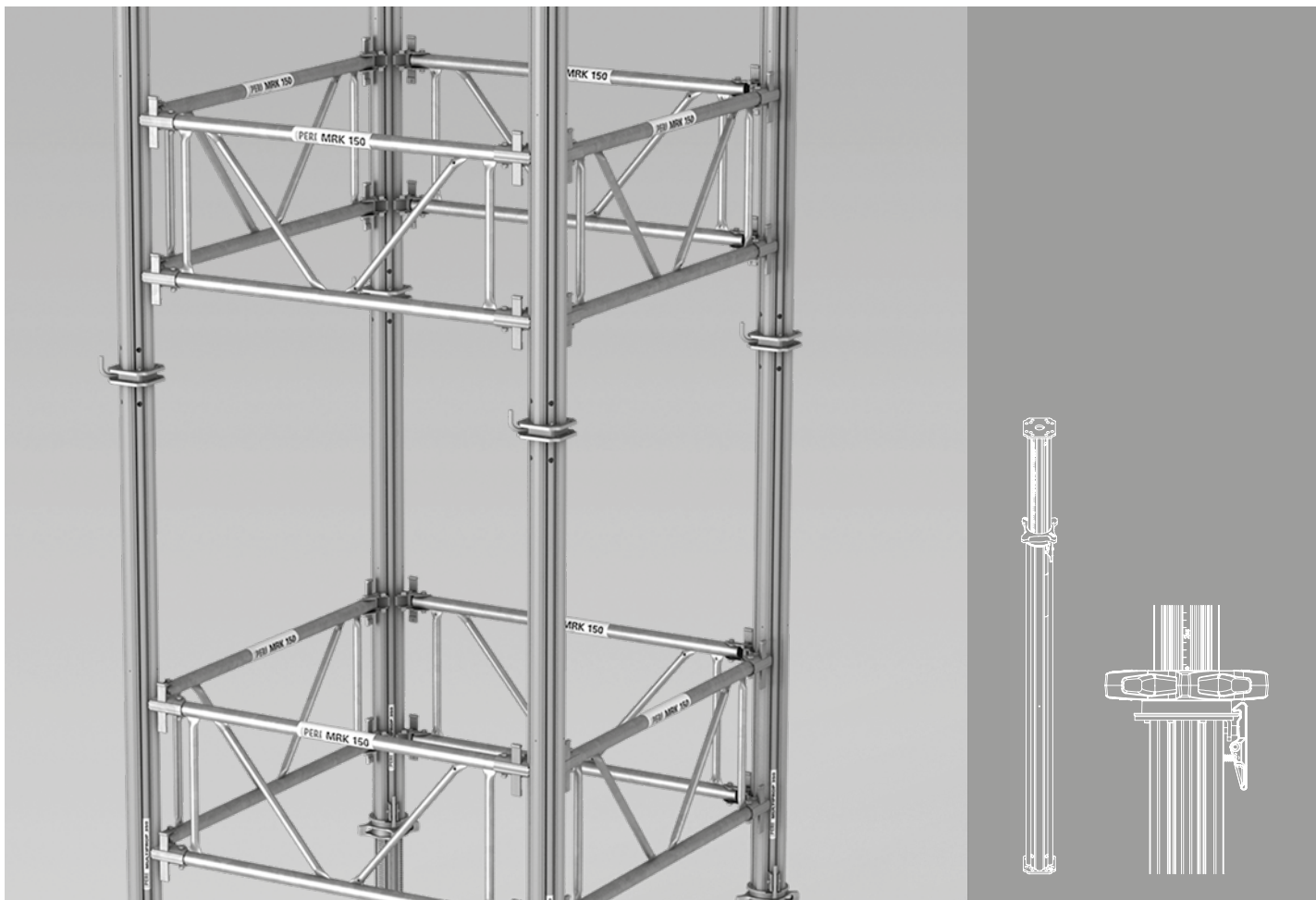

Overview

Main components	3
Accessories	4
Key	5

Introduction

Target groups	6
Additional technical documentation	6
Intended use	7
Instructions for use	7
Cleaning and maintenance instructions	8

Safety instructions

Cross-system	9
System-specific	11
Storage and transportation	11

General

Foreseeable misapplications	12
MULTIPROP variants	12

Assembly and dismantling

A1	MULTIPROP Individual Prop Adjusting the extension length	13
A2	MULTIPROP System Connecting the props Frame MRK Push Prop Head MP/SRU with Connector MP/SRU Tilting Base MKF Tilting Forkhead MKK Base MP 50	14 15 17 19 20 21
A3	Horizontal assembly With 4 legs With multiple number of legs Erecting the tower	22 25 26
A4	Vertical assembly First level Next level Additional levels	28 29 29
A5	Bracing MULTIPROP Towers Installing the Brace Connector MPR Support with Push-Pull Props Supporting in units	30 32 33
A6	MULTIPROP accessories MULTIPROP Strap U100 – U140 Connecting MULTIPROP with MPB 24 Splice MPB 24	34 34 35
A7	Dismantling Vertical dismantling Horizontal dismantling	36 37
A8	Storage and transportation	38

Application

B1	Structural Scaffold Tubes Scaffold Tube Connector MG	39
B2	Frames Use as scaffold girder	40
B3	Tables and towers Lowering Moving with the trolley and winch unit Moving along with pole Tables	41 42 42 43
	Program overview Program overview	44

Main components

1 MULTIPROP MP

- 1.1 Outer Tube
- 1.2 Inner Tube
- 1.3 Securing Hook
- 1.4 Adjusting Nut
- 1.5 Compression Spring
- 1.6 Measuring Scale
- 1.7 Rubbing Plate
- 1.8 Base Plate
- 1.9 Head Plate

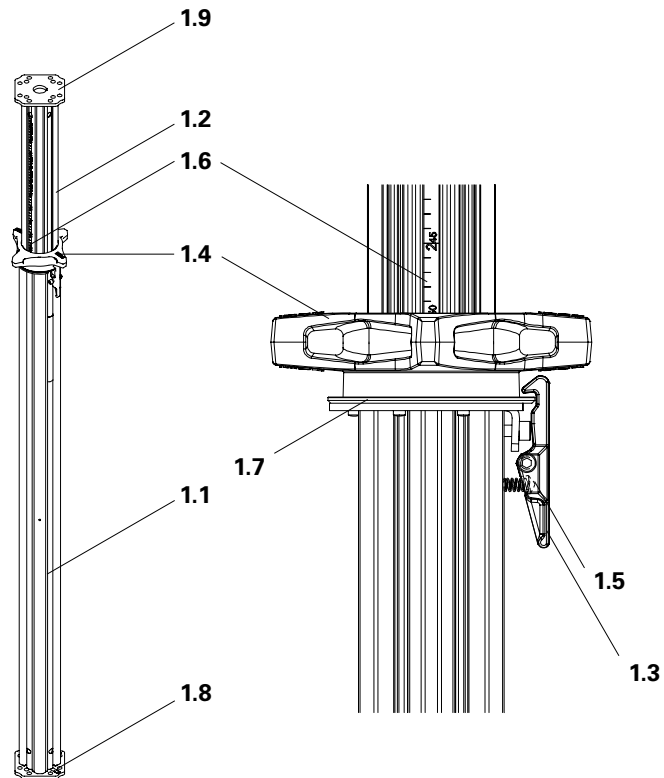

2 Frame MRK

- 2.1 Wedge Lock C
- 2.2 Wedge Lock D
- 2.3 Wedge
- 2.4 Label/Type

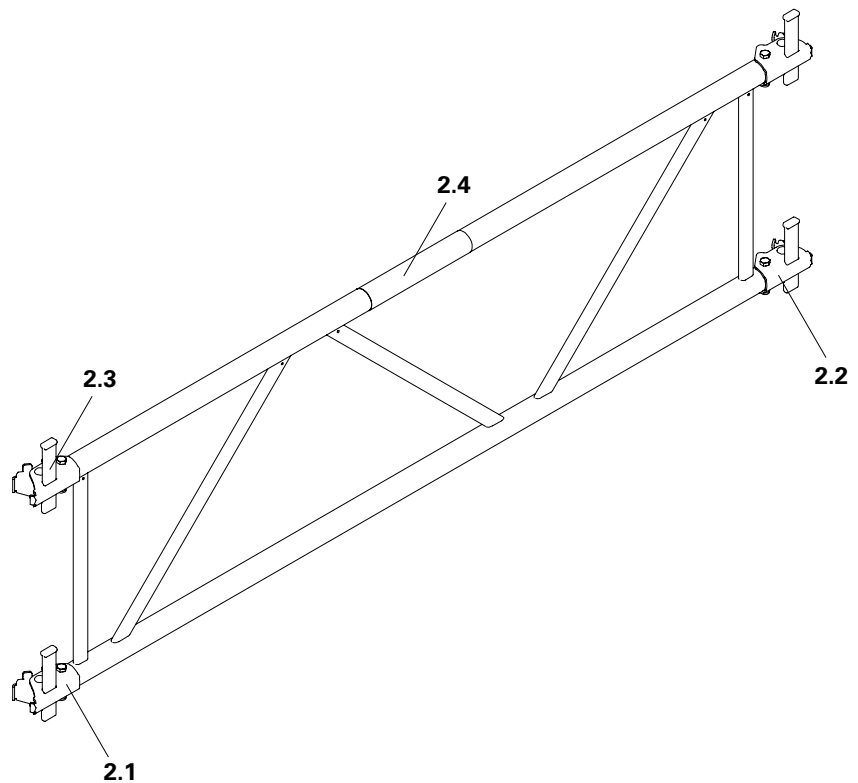

Accessories

3 Base MP 50

- 3.1 Head Plate
- 3.2 Clamping Claw
- 3.3 Centring Pin

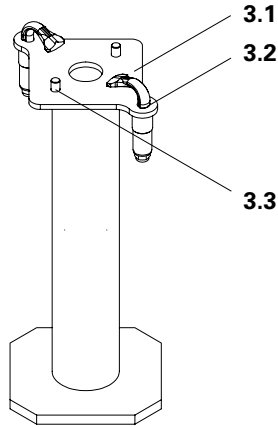

4 Tilting Base MKF

- 4.1 Head Plate
- 4.2 Clamping Claw
- 4.3 Centring Pin
- 4.4 Rotary Wing Bolt

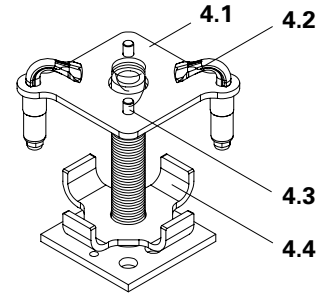

5 Tilting Forkhead MKK

- 5.1 Base Plate
- 5.2 Clamping Claw
- 5.3 Centring Pin
- 5.4 Rotary Wing Bolt

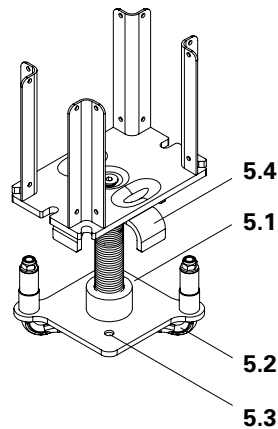

6 MULTIPROP Strap U100 – U140

- 6.1 Mounting Plate
- 6.2 Plate
- 6.3 Hex. Bolt. M16
- 6.4 Hex. Nut M16, SW 24

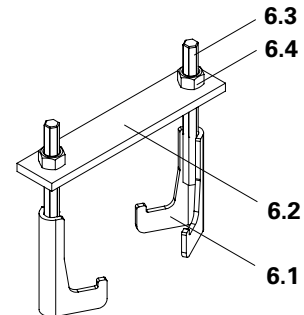

7 Connector MPV-2

- 7.1 Clamping Lever
- 7.2 Clamping Jaw
- 7.3 Centring Pin

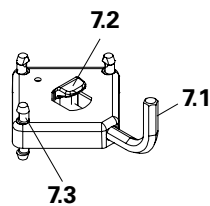

8 MULTIPROP Bolt with Nut

- 8.1 Bolt M12
- 8.2 Nut M12

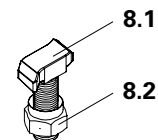

9 Push Prop Head MP/SRU

- 9.1 Fitted Pin Ø 21 with Cotter Pin

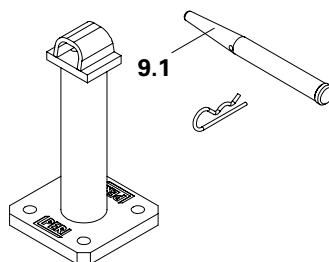

Key

Pictogram | Definition



Danger / Warning / Caution



Note



To be complied with



Load-bearing point



Visual check



Tip



Incorrect use



Safety helmet



Safety shoes



Safety gloves



Safety goggles



Personal protective equipment to prevent falling from a height (PPE)

Arrows



Arrow representing an action



Arrow representing a reaction of an action*



Arrow representing forces

* If not identical to the action arrow.

Safety instruction categories

The safety instructions alert site personnel to the risks involved and provide information on how to avoid these risks. Safety instructions are featured at the beginning of the section or ahead of the instructions, and are highlighted as follows:



Danger

This sign indicates an extremely hazardous situation which, if not avoided, will result in death or serious, irreversible injury.



Warning

This sign indicates a hazardous situation which, if not avoided, could result in death or serious, irreversible injury.



Caution

This sign indicates a hazardous situation which, if not avoided, could result in minor or moderate injury.



Note

This sign indicates situations in which failure to observe the information can result in material damage.

Format of the safety instructions



Signal word

Type and source of hazard!
Consequences of non-compliance.
⇒ Preventative measures.

Dimensions

Dimensions are usually given in cm. Other measurement units, e.g. m, are shown in the illustrations.

Conventions

- Instructions are numbered with: 1., 2., 3.
- The result of an instruction is shown by: →
- Position numbers are clearly provided for the individual components and are given in the drawing, e.g. **1**, in the text in brackets, for example (**1**).
- Multiple position numbers, i.e. alternative components, are represented with a slash: e.g. **1/2**.

Notes on illustrations

The illustration on the front cover of these instructions is understood to be a system representation only. The assembly steps presented in these Instructions for Assembly and Use are shown in the form of examples with only one component size. They are valid for all component sizes contained in the standard configuration.

To facilitate understanding, detailed illustrations are sometimes incomplete. The safety installations which have possibly not been shown in these detailed illustrations must nevertheless be available.

Target groups

Contractors

These Instructions for Assembly and Use are designed for contractors who either

- assemble, modify and dismantle the formwork systems, or
- use them, e.g. for concreting, or
- allow them to be used for other operations, e.g. carpentry or electrical work.

Competent person

(Construction Site Coordinator)

The Safety and Health Protection Coordinator*

- is appointed by the client,
- must identify potential hazards during the planning phase,
- determines measures that provide protection against risks,
- creates a safety and health protection plan,
- coordinates the protective measures for the contractor and site personnel so that they do not endanger each other,
- monitors compliance with the protective measures.

Competent persons qualified to carry out inspections

Due to the specialist knowledge gained from professional training, work experience and recent professional activity, the competent person qualified to carry out inspections has a reliable understanding of safety-related issues and can carry out inspections correctly. Depending on the complexity of the inspection to be undertaken, e.g. scope of testing, type of testing or the use of certain measuring devices, a range of specialist knowledge is necessary.

Qualified personnel

Formwork systems may only be assembled, modified or dismantled by personnel who are suitably qualified to do so. Qualified personnel must have completed a course of training** in the work to be performed, covering the following points at least:

- Explanation of the plan for the assembly, modification or dismantling of the formwork in an understandable form and language.
- Description of the measures for assembling, modifying or dismantling the formwork.

- Naming of the preventive measures to be taken to avoid the risk of persons and objects falling.
- Naming of the safety precautions in the event of changing weather conditions which could adversely affect the safety of the formwork system as well as the persons concerned.
- Details regarding permissible loads.
- Description of all other risks and dangers associated with assembly, modification or dismantling operations.



- **In other countries, ensure that the relevant national guidelines and regulations in the respective current version are complied with!**
- **If no country-specific regulations are available, it is recommended to proceed according to German guidelines and regulations.**
- **A competent person must be present on site during formwork operations.**

* Valid in Germany: Regulations for Occupational Health and Safety on Construction Sites 30 (RAB 30).

** Instructions are given by the contractor himself or a competent person selected by him.

Additional technical documentation

- Approvals:
 - Approval Z-8.22-802 MULTIPROP Shoring System
 - Approval Z-8.312-824 MULTIPROP Aluminium Prop
- Type tests:
 - MULTIPROP System
 - MULTIPROP System with Base MP 50
 - Push Prop Head MP/SRU
- Instructions for Assembly and Use:
 - MULTIPROP MP 120, 250, 350, 480, 625 Slab Props
 - SKYDECK Panel Slab Formwork
 - GRIDFLEX Girder Grid Slab Formwork
 - MULTIFLEX Girder Slab Formwork
- Instructions for Use:
 - Trolley and winch unit
 - Pallets and Stacking Devices
- Technical Data Sheet for Anchor Bolt PERI 14/20 x 130
- Design Tables 2015 – Formwork and Shoring
- Brochure:
 - MULTIPROP Aluminium Slab Prop

Intended use

Product description

PERI products have been designed for exclusive use in the industrial and commercial sectors only by suitably trained personnel.

These Instructions for Assembly and Use describe the standard configuration for shoring in accordance with the provisions of DIN EN 12812. Shoring handles static loads and is not suitable for lifting or lowering components and constructions.

MULTIPROP Slab Props MP can be used in combination with the Frame MRK as a table or tower to transfer vertical loads.

The outer tubes of the MULTIPROP Slab Props are powder-coated.

The MRK frames can be mounted on both the outer and inner tube without changing the system dimensions.

The integrated measuring scale and free-running collar allow accurate and fast height adjustment. The MULTIPROP Slab Prop has a fail-safe feature which prevents the inner tube from unintentionally slipping out. Markings on the outer tubes facilitate precise assembly of the MRK frames. Only a hammer is required for the assembly work.

Features

The MULTIPROP System is used in shoring construction in a planned perpendicular position to transfer vertical loads.

Main components

MULTIPROP 120, L = 0.80 – 1.20 m
MULTIPROP 250, L = 1.45 – 2.50 m
MULTIPROP 350, L = 1.95 – 3.50 m
MULTIPROP 480, L = 2.60 – 4.80 m
MULTIPROP 625, L = 4.30 – 6.25 m

MULTIPROP Frame MRK, steel

Frame MRK 62.5
Frame MRK 75
Frame MRK 90
Frame MRK 120
Frame MRK 137.5
Frame MRK 150

MULTIPROP Frame MRK, aluminium

Frame MRK 201.5
Frame MRK 210
Frame MRK 225
Frame MRK 230
Frame MRK 237
Frame MRK 266
Frame MRK 296
Frame MRK 350

System dimensions

Assembly heights as individual props according to the permissible extension lengths 0.80 m – 6.25 m or 1.30 m – 6.75 m together with Base MP 50.

Assembly heights as a system with Frame MRK up to a maximum of 14.40 m, or 14.90 m with Base MP 50.

In the ground plan, square or rectangular depending on the Frame MRK used, from 0.625 m to 3.50 m.

Permissible load-bearing capacities = leg loads

Corresponding to Design Class B1 in accordance with DIN EN 12812.

The load-bearing capacity of the shoring towers in the MULTIPROP System is dependent on the position of the MULTIPROP Frame MRK.

The values are stated in the relevant current versions of the type test.

Instructions for use

Use in a way not intended, deviating from the standard configuration or the intended use according to the Instructions for Assembly and Use, represents a misapplication with a potential safety risk, e.g. risk of falling.

Deviations from the standard configuration must be verified for the application by means of separate strength and stability calculations (Industrial Safety Regulation Appendix 1, No. 3.2.1 and explicitly reflected in the assembly instructions.)

Only PERI original components may be used. The use of other products and spare parts is not allowed.

Changes to PERI components are not permitted.

The system described in these Instructions for Assembly and Use may contain patent-protected components.

Cleaning and maintenance instructions

Clean the panels after each use to maintain the value and usability of the PERI products over the long term.

Some repair work may also be inevitable due to the tough working conditions. The following points should help to keep cleaning and maintenance costs as low as possible.

Never use steel brushes or hard metal scrapers to clean powder-coated or galvanised components.

Mechanical components, e.g. spindles, must be cleaned of dirt or concrete residue before and after use, and then greased with a suitable lubricant.

Provide suitable support for the components during cleaning so that no unintentional change in their position is possible.

Do not clean components suspended on crane lifting gear.

Any repairs to PERI products are to be carried out by PERI qualified personnel only.

Cross-system



Safety instructions apply to all phases of the system.

General

The contractor must ensure that the Instructions for Assembly and Use supplied by PERI are available at all times and understood by the site personnel.

These Instructions for Assembly and Use can be used as the basis for creating a risk assessment. The risk assessment is compiled by the contractor. However, these Instructions for Assembly and Use do not replace the risk assessment!

Refer to and comply with the safety instructions and permissible loads.

For the application and inspection of PERI products, the current safety regulations and guidelines valid in the respective countries must be observed.

Materials and working areas are to be inspected before each use and assembly, for:

- damage,
- stability and
- functional correctness.

Damaged components must be exchanged immediately on site and may no longer be used.

Safety components are to be removed only when they are no longer required.

When on slab formwork, scaffolds and working platforms:

- do not jump,
- do not run,
- do not drop anything from or onto it.

Components provided by the contractor must comply with the characteristics stipulated in these Instructions for Assembly and Use and all applicable laws and standards. Unless otherwise indicated, the following applies in particular:

- Timber components: Strength Class C24 for Solid Wood according to EN 338.
- Scaffold tubes: galvanised steel tubing with minimum dimensions $\varnothing 48.3 \times 3.2$ mm according to EN 12811-1:2003 4.2.1.2.
- Scaffold tube couplings according to EN 74-1 and EN 74-2.

Deviations from the standard configuration are only permitted after a further risk assessment has been carried out by the contractor.

Appropriate measures for working and operational safety, as well as stability, are defined on the basis of this risk assessment.

Corresponding proof of stability can be provided by PERI on request, if the risk assessment and resulting measures to be implemented are made available.

Before and after exceptional occurrences that may have an adverse effect on the safety of the scaffolding system, the contractor must immediately

- produce another risk assessment and make use of its results to take suitable steps to guarantee the stability of the scaffolding system,
- arrange for an extraordinary inspection to be carried out by a competent person qualified to do so. The aim of this inspection is to identify and rectify any damage in good time in order to guarantee safe use of the scaffolding system.

Exceptional events could be:

- accidents,
- long periods of non-use,
- natural events, e.g. heavy rainfall, icing, heavy snowfall, storms or earthquakes.

Assembly, modification and dismantling work

Assembly, modification or dismantling of climbing systems may only be carried out by qualified persons under the supervision of a competent person. The qualified personnel must have received appropriate training for the work to be carried out with regard to specific risks and dangers.

On the basis of the risk assessment and Instructions for Assembly and Use, the contractor must create installation instructions, in order to ensure safe assembly, modification and dismantling of the formwork system.



The contractor must ensure that the personal protective equipment required for the assembly, modification or dismantling of the climbing formwork, e.g.

- safety helmet,
- safety shoes,
- safety gloves,
- safety goggles,

is available and used as intended.



If personal protective equipment against falling from a height (PPE) is required or specified in local regulations, the contractor must determine appropriate attachment points on the basis of the risk assessment. The PPE against falling to be used is determined by the contractor.

The contractor must

- provide safe working areas for site personnel, which are to be reached through the provision of safe access ways. Areas of risk must be cordoned off and clearly marked.
- ensure stability during all stages of construction, in particular during assembly, modification and dismantling operations.
- ensure and provide evidence that all loads that occur are transferred safely.

Use

Every contractor who uses or allows the scaffolding systems to be used, is responsible for ensuring that the equipment is in good condition.

If the scaffolding system is used successively or at the same time by several contractors, the health and safety coordinator must point out any possible mutual hazards and all work must be then coordinated.

System-specific

Retract components only when the concrete has sufficiently hardened and the person in charge has given the go-ahead for striking to take place.

Anchoring is to take place only if the anchorage has sufficient concrete strength.

The load-distributing support used, e.g. planking, must match the respective base. If multiple layers are required, planks are to be arranged crosswise.

Tighten couplings with screw closures using 50 Nm. This corresponds to a force of 20 kg using a lever arm length of 25 cm.

Secure the wedges using a 500 g hammer.

Storage and transportation

Store and transport components ensuring that no unintentional change in their position is possible. Detach lifting accessories and slings from the lowered components only if they are in a stable position and no unintentional change is possible.

Do not drop the components.

Use PERI lifting accessories and slings and only those load-bearing points provided on the component.

During the moving procedure

- ensure that components are picked up and set down so that unintentional falling over, falling apart, sliding, falling down or rolling is avoided.
- no persons are allowed to remain under the suspended load.

Always guide pre-assembled scaffolding bays, scaffolding units or scaffolding sections with ropes when moving them by crane.

The access areas on the construction site must be free of obstacles and tripping hazards, as well as being slip-resistant.

For transportation, the base must have sufficient load-bearing capacity.

Use original PERI storage and transport systems, e.g. pallet cages, pallets or stacking devices.

Foreseeable misapplications



Applications of this kind or a similar kind are prohibited!

Do not use slab props with broken or damaged nuts!

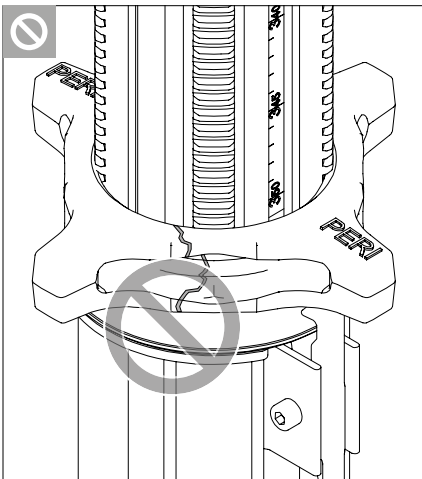

Fig. A4.01a

Do not use slab props with bent end plates or cracked seams on the end plates!

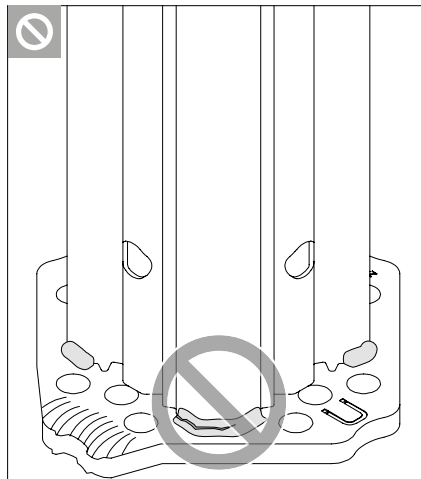

Fig. A4.01b

Do not use slab props with bent rubbing plates!

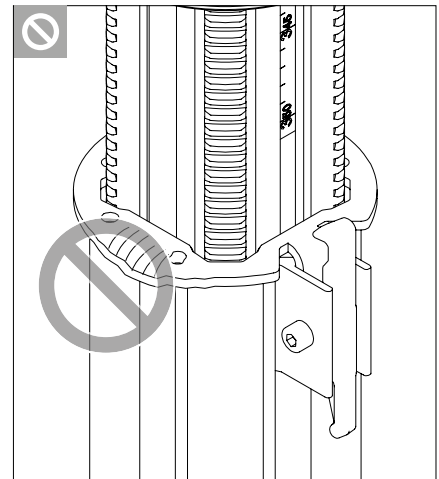
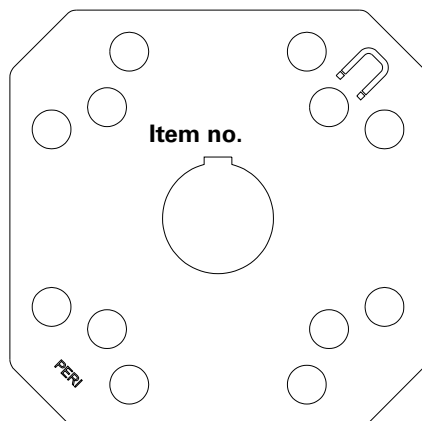

Fig. A4.01c

MULTIPROP variants

Shape of the End Plates according to DIN EN 16031



Shape of the End Plates according to approval

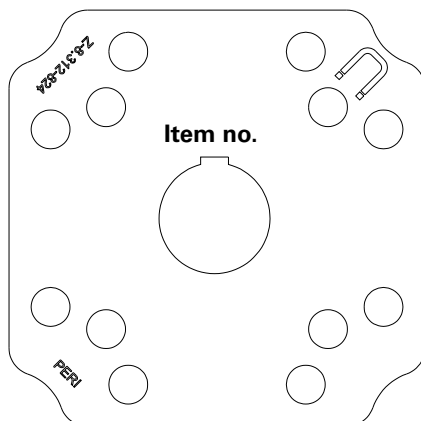

Props from recent production are manufactured in accordance with DIN EN 16031 and therefore no longer require approval. Both variants can be used without restrictions in accordance with the Instructions for Assembly and Use.

Adjusting the extension length



- Lift the prop in such a way that the adjusting nut runs downwards.
- The prop can be continuously readjusted by means of the adjusting nut if partially loaded up to 15 kN.
- Use a Wing Nut Spanner HD in order to allow the prop to spindle unencumbered with loads > 60 kN.
- From time to time, grease the contact surface between the adjusting nut and the rubbing plate with a suitable lubricating agent to ensure easier handling.

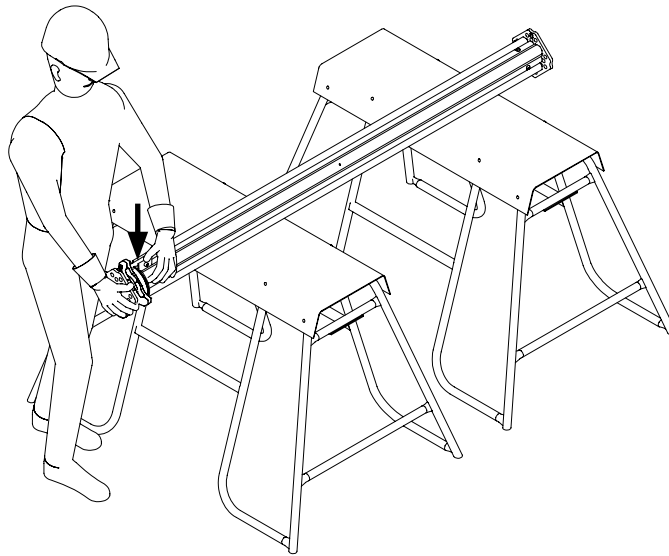

Fig. A1.01



The pallets serve as a secure prop support.

Preparation

Place the MULTIPROP Prop with retracted inner tube on an appropriately-positioned trestle/pallet. (Fig. A1.01)

Rough adjustment of the extension length

1. Press securing hook (1.3). The adjusting nut (1.4) is disconnected. (Fig. A1.01a)
2. Extend inner tube (1.2) to the required prop length. (Fig. A1.01a + A1.01b)
3. Adjust to the exact prop length by means of the adjusting nut on the integrated measuring scale (1.6) (36 mm adjusting range per turn).
4. Push in the inner tube until the adjusting nut is lying against the rubbing plate (1.7). (Fig. A1.02)
5. Lock the securing hook in place.

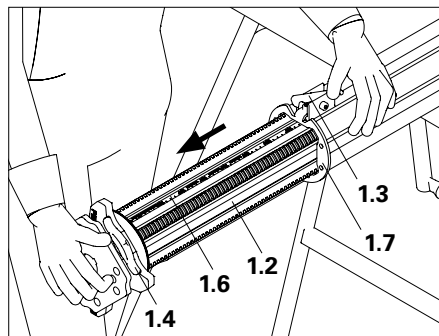

Fig. A1.01a

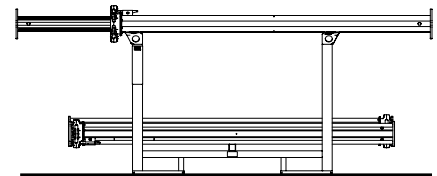

Fig. A1.01b

The prop has now been adjusted.



Is the securing hook locked?



Now pre-assemble Tilting Base MKF and Tilting Forkhead MKK.

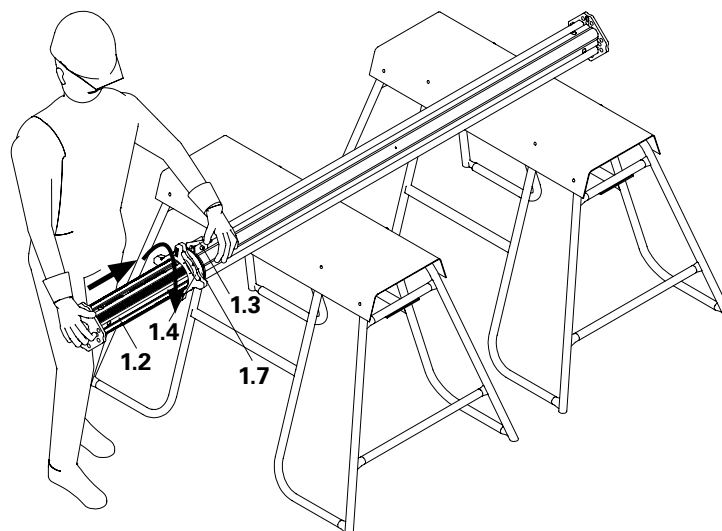

Fig. A1.02

Connecting the props



Extended props may only be used for towers!
 Brace with Frame MRK!
 Check connections to ensure fittings are tight!

Connector MPV-2

The Connector MPV-2 (7) connects two MULTIPROP Props with end plate thicknesses of 10 mm.

Assembly

1. Insert centring pins (7.3) into the drilled holes of the prop base (1.8) or head plate (1.9).
2. Place the second prop on the centring pins of the Connector MPV.
3. Turn clamping lever (7.1) to the right and firmly tighten.
4. Engage clamping jaws (7.2) in the central bore of the prop.
 (Fig. A2.01)

→ The props are now connected.

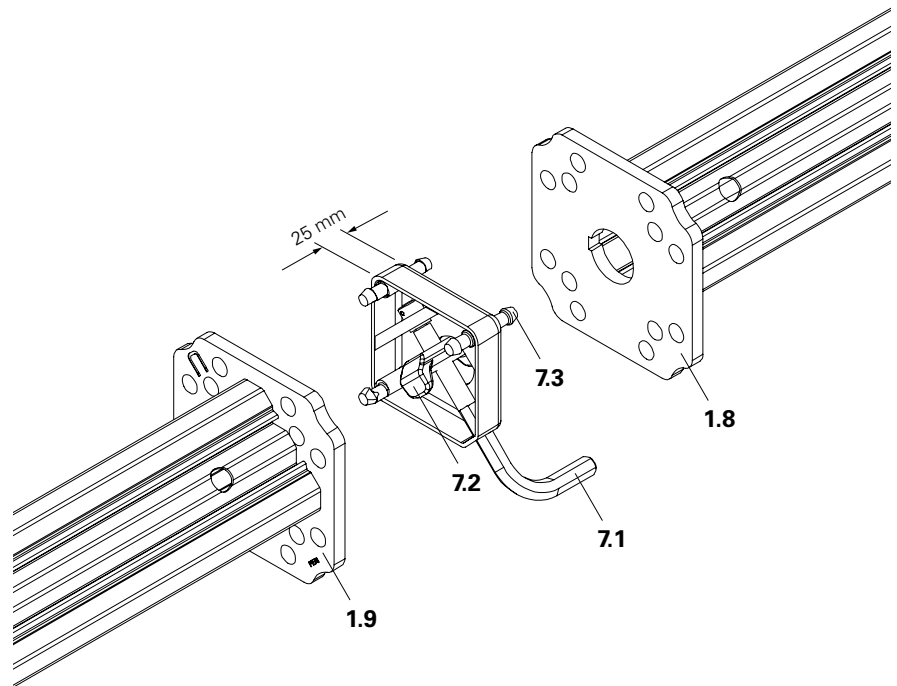

Fig. A2.01

The tower height can be adjusted by means of the integrated measuring scale. An extra 2.5 cm must be added for each MPV connector.

MULTIPROP Bolt with Nut

As an alternative to the Connector MPV-2, the end plates of both props can be connected using two diagonally-arranged MULTIPROP Bolts with Nuts. (Fig. A2.02 + A2.02a)

Assembly

1. From the bottom, insert the bolt (8.1) through the drilled hole.
2. Open nut (8.2) with the collar facing the head plate (1.9) and tighten, AF 19.

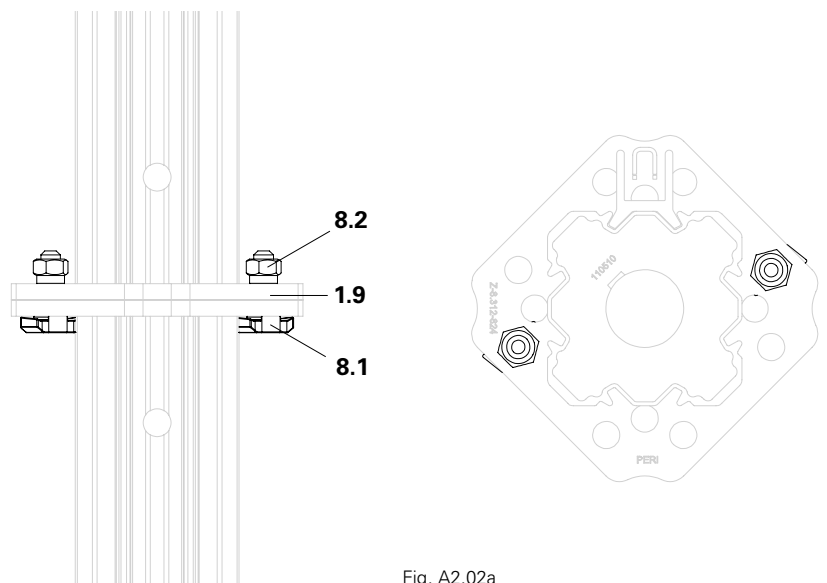

Fig. A2.02a

Fig. A2.02

Frame MRK



Set the MULTIPROP Frames MRK down in a secure position so that they cannot tip over!
Do not damage the wedge connection!

Assembly

Always mount the MRK frames (2) on the props (1) in such a way that the wedge can be hit into position with the hammer from top to bottom. (Fig. A2.03)

If required, use the tripod as an erection aid during assembly.

1. Open wedge connection C (silver) (2.1) or D (yellow or black) (2.2). The wedge (2.3) is at the top. (Fig. A2.04)
 2. Engage wedge connection in the profile grooves of the MP Tubes. (Fig. A2.05)
 3. Keep the wedge connection closed.
 4. Firmly strike the wedge with the hammer.
 5. Close the other wedge connections in the same way.
- The frame is mounted on the prop. (Fig. A2.05)

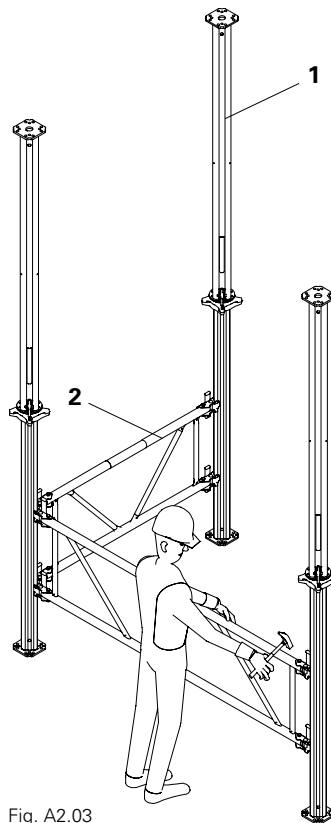

Fig. A2.03

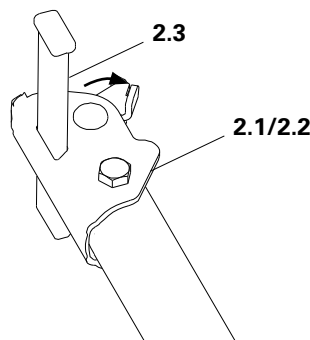

Fig. A2.04

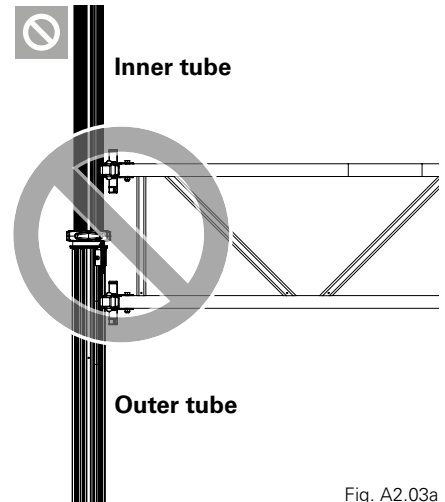
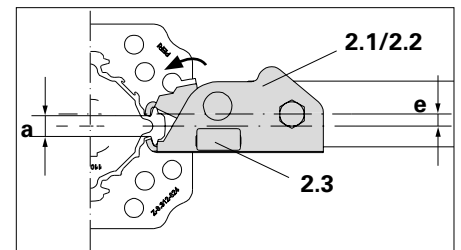

Fig. A2.03a

Inner tube



Outer tube

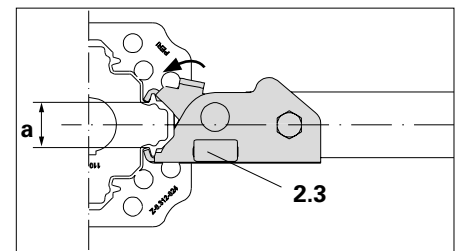

Fig. A2.05



Do not mount the MRK frame in the inner tube/outer tube transition area. (Fig. A2.03a)



If the wedge slips through, there is no clamping effect!

- In this case, release the wedge and reconnect.
- For a tight connection to the outer or inner tube with jaw opening variant "a", two wedge courses are integrated in the wedge (2.3) itself (Fig. A2.05 Jaw opening "a")
- In the clamping area, the prop profile must be clean, e.g. free of concrete residues. (Fig. A2.06)

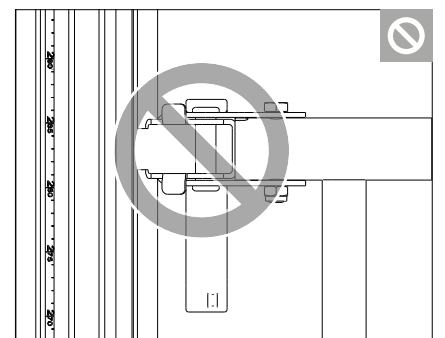
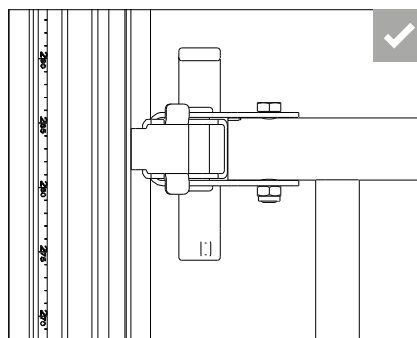

Fig. A2.06

Arrangement of the Frames MRK

Universally valid

The arrangement of the MRK frames is shown in the corresponding diagram contained in the type test.

Markings on the outer tube

Arrange the MRK frames at the circular-shaped recesses (1.10) of the outer tube. This results in a distance of 40 cm to the base plate. (Fig. A2.07a + A2.07b)

Outer tube top

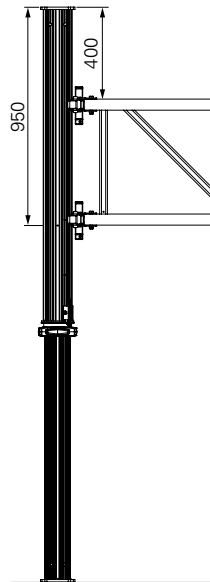

Fig. A2.07a

Outer tube bottom

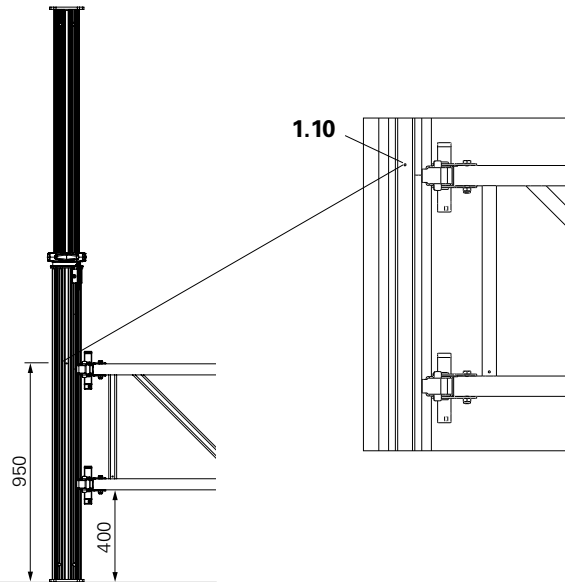

Fig. A2.07b

Outer tube + Inner tube



Only wedge connections of the same colour are permissible at a connection point! (Fig. A2.08)

When inserted, the wedges (2.3) of the wedge connections must always be pointed downwards so that any self-actuating loosening is not possible!

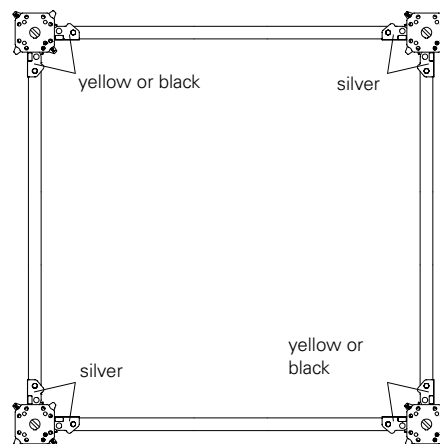

Fig. A2.08

Use of Frames \leq MRK 90

Frames \leq MRK 90 must be mounted on the inner tube in the opposite direction to the outer tube, to prevent twisting of the tower. Thus the colour of the wedge connections on the tube changes over the height of the tower. (Fig. A2.09a + A2.09b)

Outer Tube \leq MRK 90

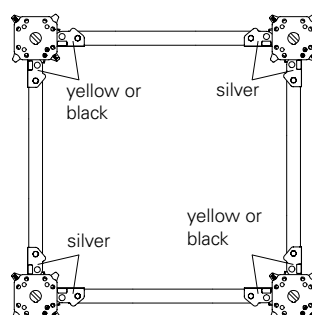

Fig. A2.09a

Inner Tube \leq MRK 90

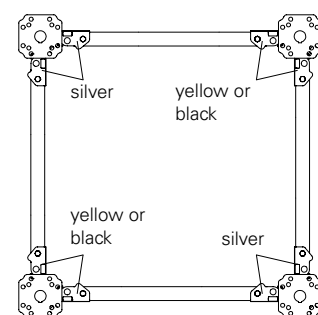

Fig. A2.09b

Push Prop Head MP/SRU with Connector MP/SRU

- The Push Prop Head MP/SRU (9) with Connector MP/SRU (17) is used to brace inclined Main Beams SRU on shoring towers. (Fig. A2.10)
- The Push Prop Head can also be used for erecting towers on inclined surfaces. (Fig. A2.11)
- The Push Prop Head MP/SRU can usually be bolted directly onto the Main Beam SRU.
- The Connector MP/SRU serves as a compensatory element between the Push Prop Head and the inclined main beams irrespective of the prop grid.
- Any desired inclination and frame size is possible by plugging holes "A or B" for the Push Prop Head and holes 1, 2, 3 or 4 in the main beam for Connector MP/SRU. (Fig. A2.10a + A2.10b)

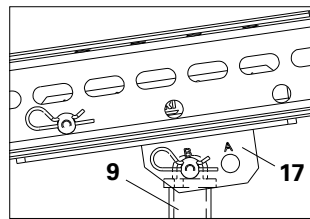

Fig. A2.10a

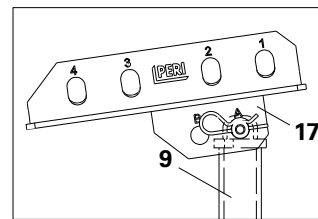

Fig. A2.10b

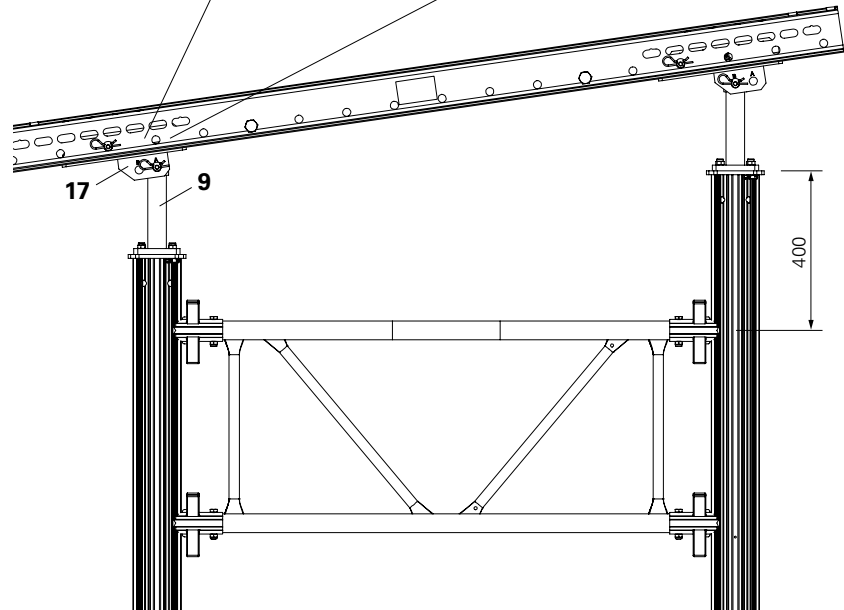

Fig. A2.10

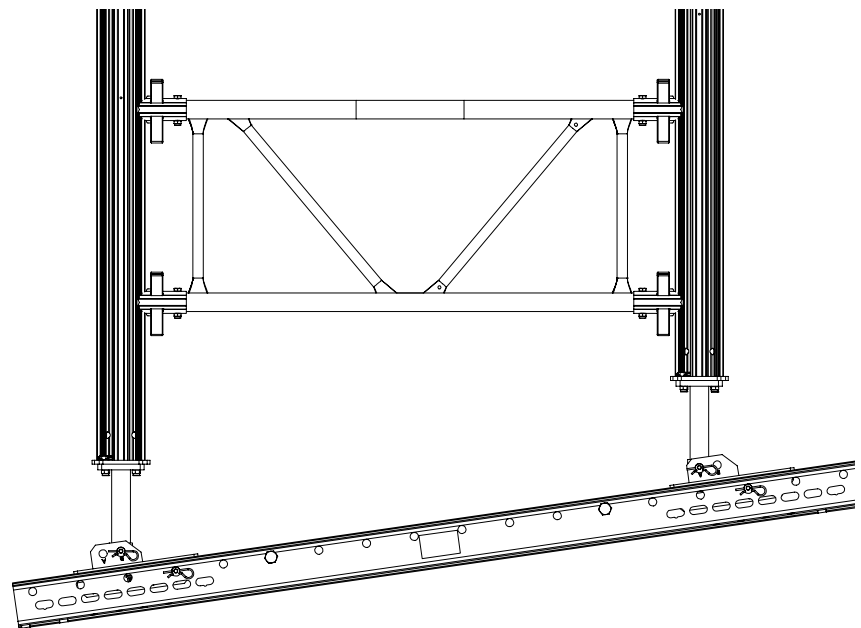

Fig. A2.11

Technical data

See type test for the Push Prop Head MP/SU with MULTIPROP for permissible load-bearing capacity.



- Always position screw head on the prop!
- Check nuts to ensure fittings are tight!

Assembly

1. Secure Push Prop Head MP/SRU (**9**) diagonally on the end plate of the MULTIPROP Prop by means of 2 MULTIPROP Bolts with Nuts (**8**). (Fig. A2.12 + A2.13)
2. Spindle out MULTIPROP Slab Prop to required length.
3. Secure Push Prop Head MP/SRU on Steel Waler SRU using bolts and cotter pins (**9.1**).

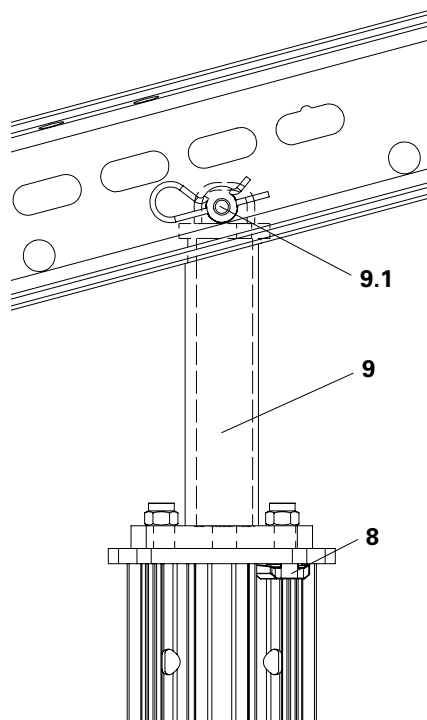
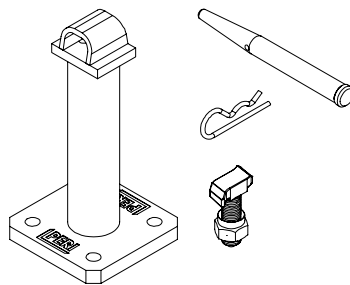

Fig. A2.12

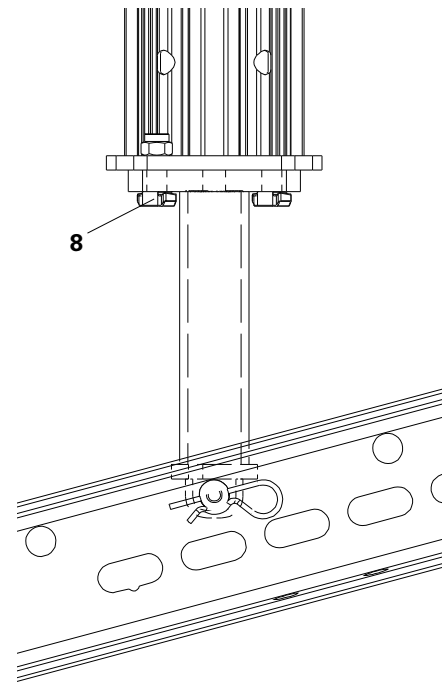

Fig. A2.13

Tilting Base MKF

The Tilting Base MKF (4) with quick-action clamp coupling can be pivoted on all sides by up to 3°. This means that MULTIPROP props can be positioned on inclined surfaces. (Fig. A2.14)

Technical data

Max. permissible load-bearing capacity 60 kN.



Use Tilting Base MKF only with braced props!

The first Frame MRK can be mounted a maximum of 40 cm above the upper edge of the base plate!

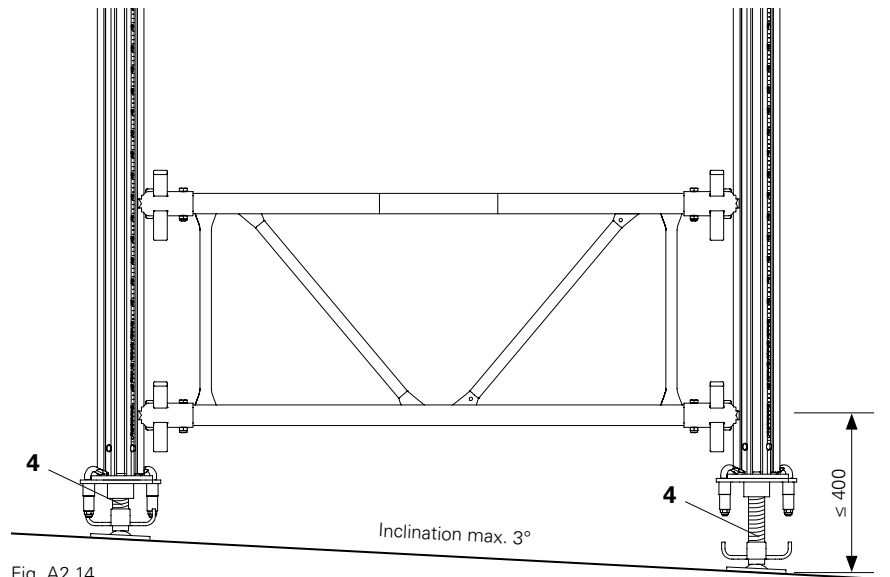

Fig. A2.14

Assembly

1. Insert centring pins (4.3) of the head plate (4.1) into the drilled holes of the prop base plate (1.8) or head plate (1.9).
2. Hit clamping claws (4.2) with a hammer over the prop base or head plate. Tilting Base MKF is connected to the prop. (Fig. A2.15)
3. Spindle Tilting Base MKF to required dimension using the rotary wing bolt (4.4).
Max. spindle adjustment range: 100 mm.

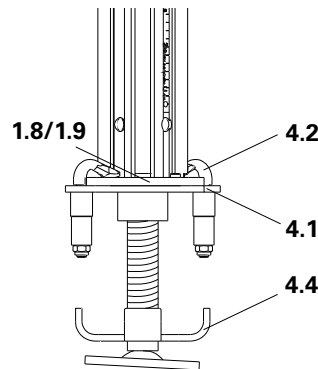

Fig. A2.15

Releasing



Spindle props without load!

1. Open clamping claws (4.2) using a hammer to release the Tilting Base MKF from the prop.
2. Remove Tilting Base MKF.

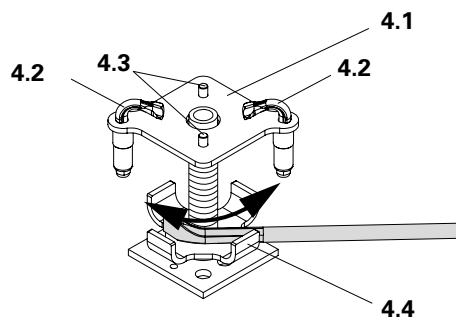

Fig. A2.16

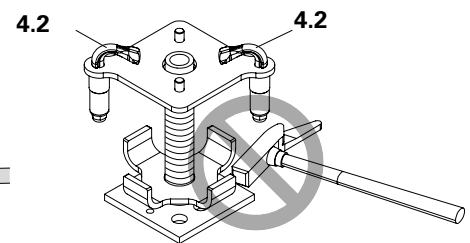

Fig. A2.16a



When under load, the rotary wing bolt can be turned by means of a nail puller. (Fig. A2.16)



Never loosen the rotary wing bolt with force. Risk of breakage! (Fig. A2.16a)

Tilting Forkhead MKK

Technical data

Permissible load-bearing capacity:
see MULTIPROP System type test.

The Tilting Forkhead MKK (5) with quick-action clamp coupling can be pivoted on all sides by up to 3°. It serves to reliably support one or two GT 24 or VT 20 girders for non-horizontal slab formwork. (Fig. A2.17)

Alternatively:
Alu Beam MPB 24 can be used as a main beam.

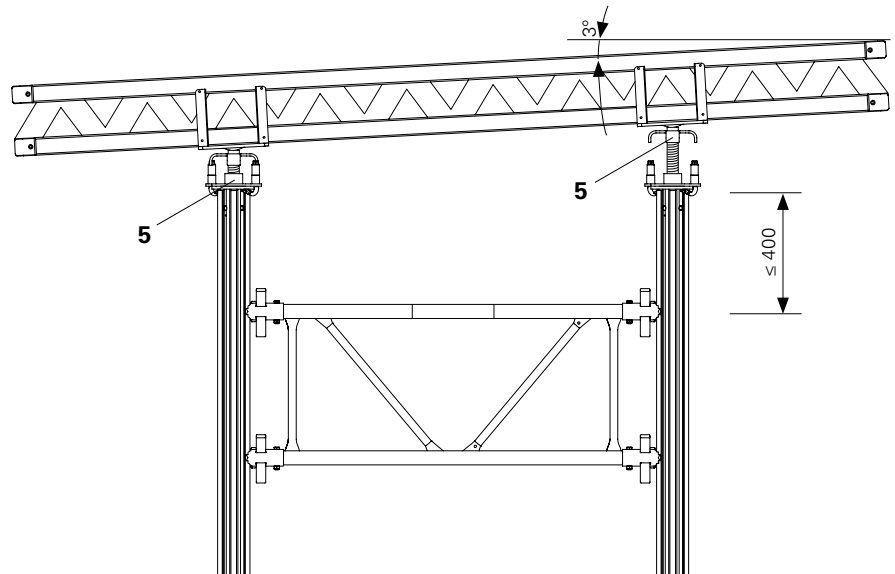

Fig. A2.17

Assembly

1. Insert the centring pins (5.3) of the base plate (5.1) into the drilled holes of the base plate (1.8) or head plate (1.9) of the slab prop.
2. Hit clamping claws (5.2) with a hammer over the prop base or head plate.
3. Spindle Tilting Forkhead MKK to required dimension using the rotary wing bolt (5.4).
Max. spindle adjustment range: 100 mm. (Fig. A2.18)



- Potential horizontal forces must be safely transferred.

Releasing



Spindle props without load!

1. Open clamping claws (5.2) using a hammer to release the Tilting Base MKF from the prop.
2. Remove Tilting Forkhead MKK.

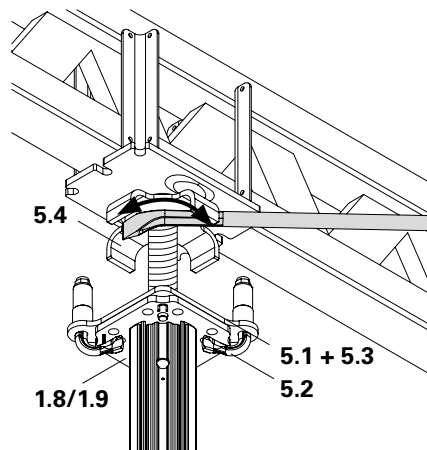

Fig. A2.18



When under load, the rotary wing bolt can be turned by means of a nail puller.

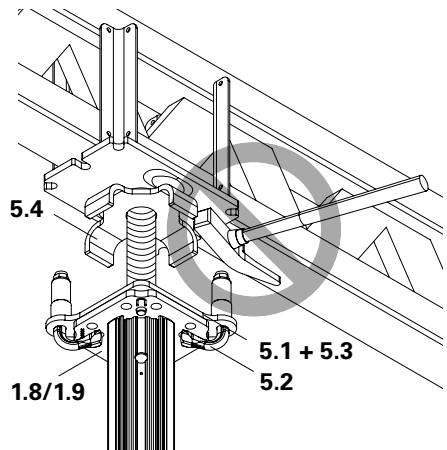

Fig. A2.18a



Never loosen the rotary wing bolt with force. Risk of breakage! (Fig. A2.18a)

Base MP 50

Technical data

Permissible load-bearing capacity,
see type test:

- MULTIPROP System with Base MP 50
- MULTIPROP Slab Props with Base MP 50.



- Used to extend the Slab Prop by 50 cm.
- Automatic centring of the slab prop by means of centring pins.
- Two clamping claws connect the Base MP 50 with the slab prop.
- The MULTIPROP Slab Prop can be mounted on the Base MP 50 with the inner or outer tube.

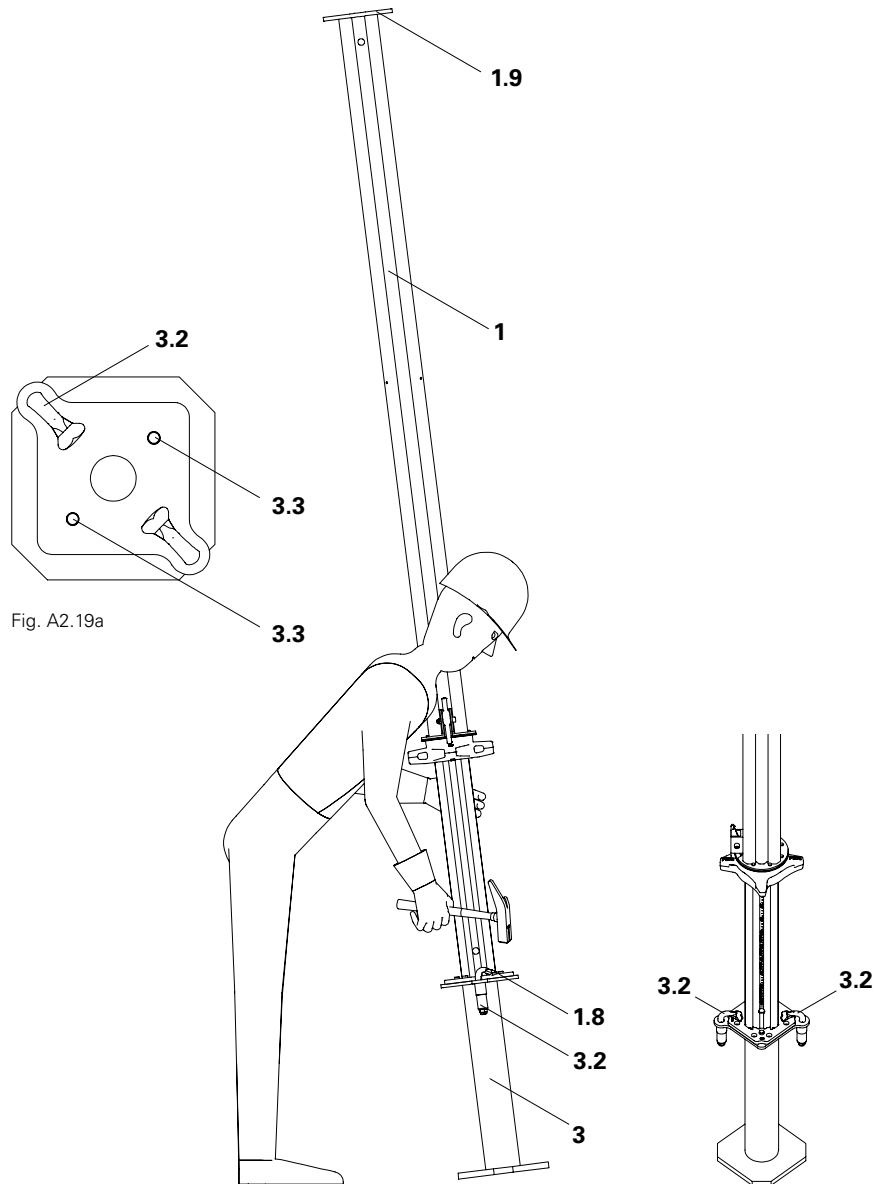

Fig. A2.19a

Assembly

1. Place Slab Prop (1) on the Base MP 50 (3).
2. Centring pins (3.3) of the base engage with the drilled holes of the base plate (1.8) or head plate (1.9) of the slab prop. (Fig. A2.19a)
3. Hit clamping claws (3.2) with a hammer over the base plate or head plate of the slab prop. (Fig. A2.19) Base MP 50 is connected to the slab prop.



Is the full surface of both clamping claws resting on the head and base plates?

Releasing



Spindle props without load!

1. Open clamping claws (3.2) using a hammer.
2. Remove the Base MP 50.

Fig. A2.19

Assembly with 4 legs

For horizontal assembly, a flat and even assembly area is required.



Preparation

1. Adjust length of props as described in A1.
2. Pre-position props **(1)** and Frame MRK **(2)** on the ground:
 - The inner tubes **(1.2)** of the top and bottom props are pointing outwards. This means that any unevenness in the ground can be more easily compensated and the formwork can be levelled.
 - The base plates **(1.8)** must rest on the ground with one edge surface. (Fig. A3.01a)

- The prop joints are positioned on one level. The alignment of the prop axes is to be constantly monitored in order to avoid time-consuming corrections.
- With rectangular-shaped shoring towers, the wider frame is positioned on the ground. (Fig. A3.01)
- The number and position of the Props MP and the Frames MRK must correspond to the respective assembly variant of the type test.



Checking assembly is easier with the measuring scale **(1.6)** facing towards the centre of the tower. (Fig. A3.01b)

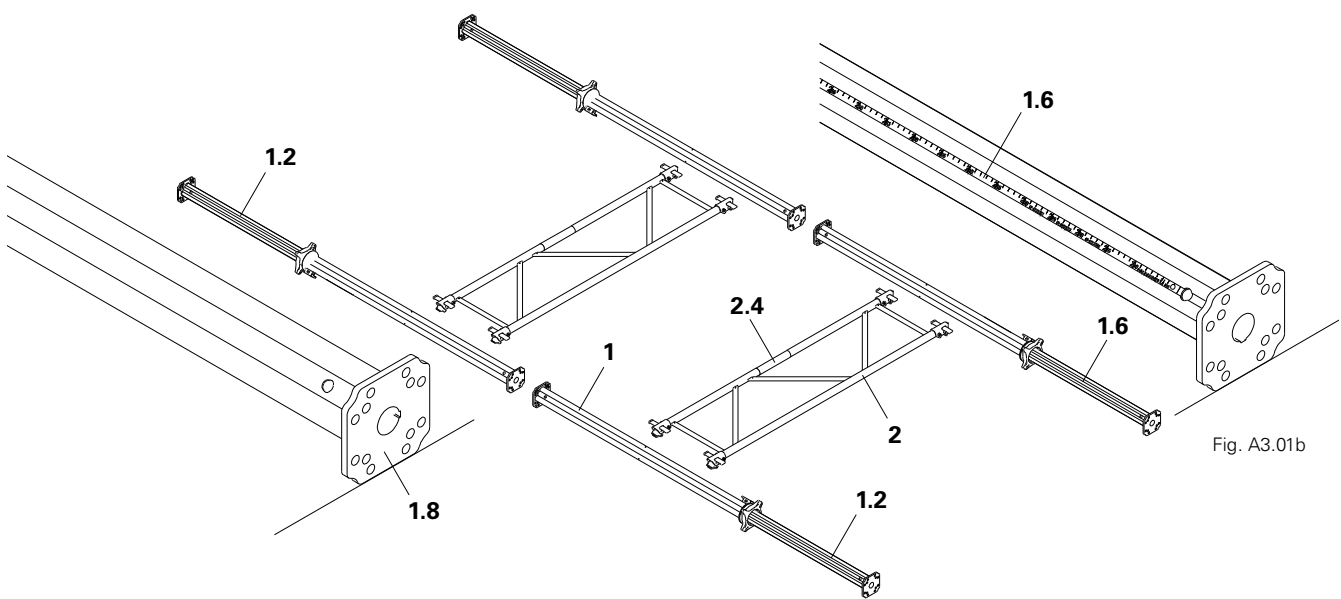

Fig. A3.01a

Fig. A3.01b

Assembling the tower

1. Connect the props to each other.
2. Mount the frames. The wider frame is positioned on the ground.
(Fig. A3.02)

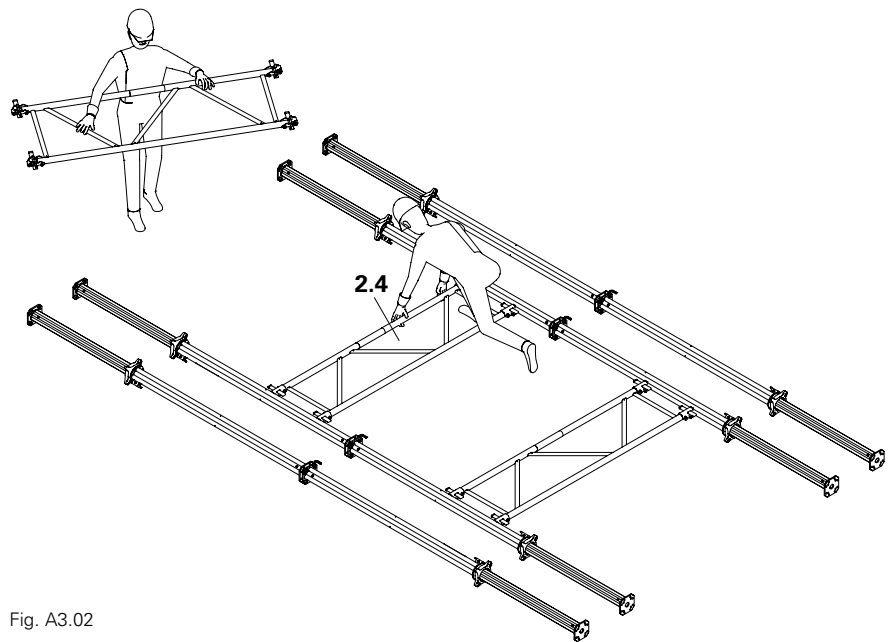

Fig. A3.02

3. Mount lateral frames.
(Fig. A3.03)

- Yellow or black to yellow or black and silver to silver.
- Close the wedges in the direction of the assembly area.



Check the colour of the wedge connections as well as the wedge direction.



The text on the adhesive labels (**2.4**) is legible from the subsequent assembly area!

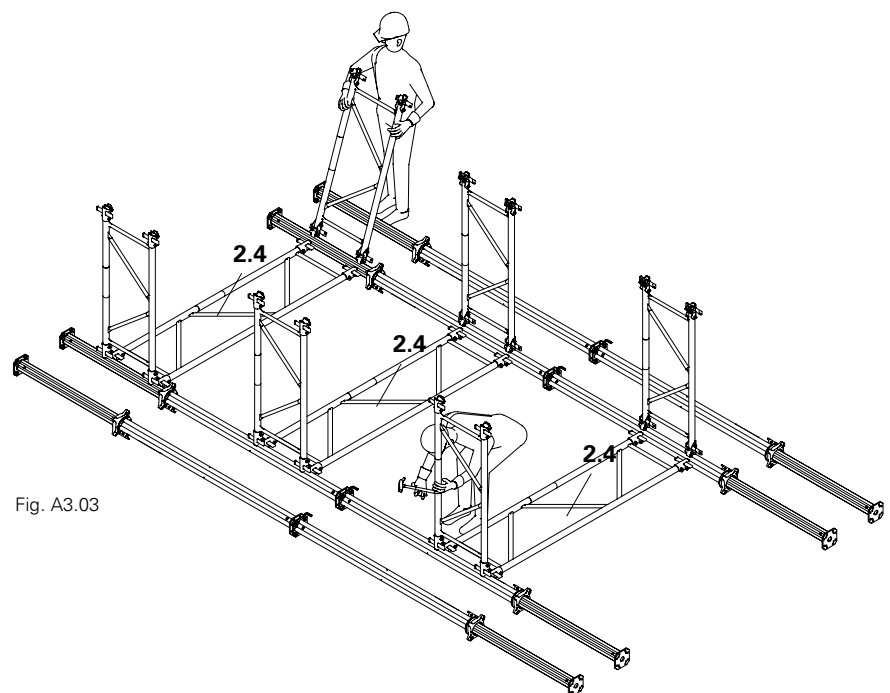

Fig. A3.03

4. Insert second pair of props into the opened wedge connections of the frames.
 5. Close wedge connections and hammer in wedges.
 6. Install top frame. (Fig. A3.04)
- The tower has now been assembled.



Before erecting, ensure that all adjusting nuts are resting against their respective rubbing plates. Are the securing hooks closed?



- With larger units, the upper props can be inserted individually. Connect the props to each other before connecting to the frames.
- For towers with heights > 7.0 m, a scaffold tube $\varnothing 48.3 \times 3.2$ is to be attached to the MRK frames as a horizontal brace (**10**) by means of swivel couplings at around half the tower height to safeguard the cross-sectional form. (Fig. A3.05)

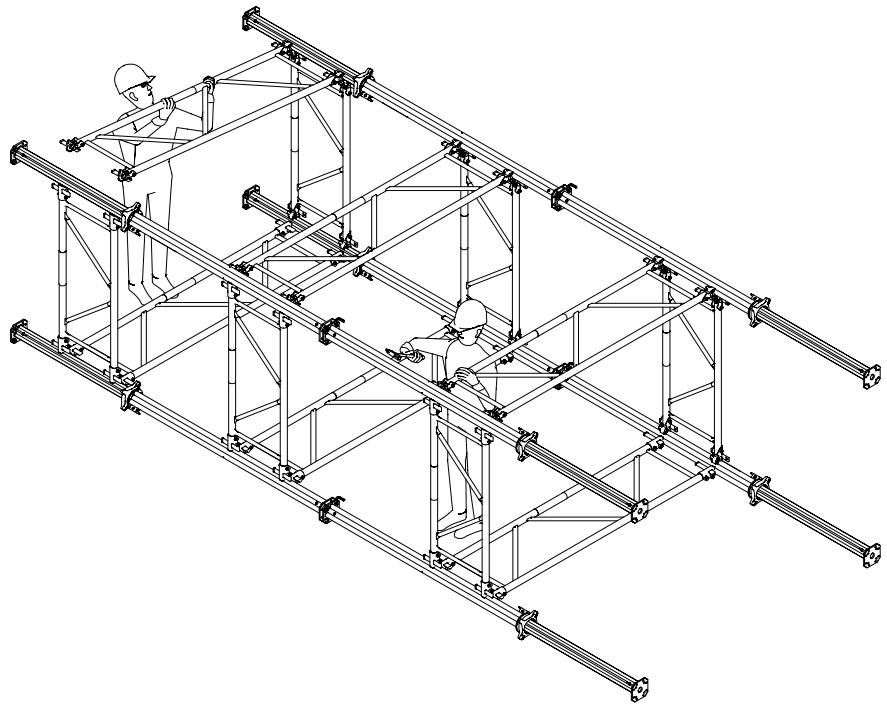

Fig. A3.04

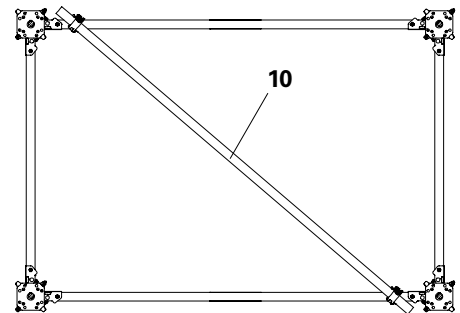

Fig. A3.05

Assembly with multiple number of legs – example



The instructions provided in Section A2 apply, Arrangement of the Frames MRK



The following should also be taken into account:

- The Frames MRK (**2**) must be installed in a consistent “windmill” design.
- The assemblies are to be braced with diagonally-positioned scaffold tubes \varnothing 48.3 (**10**) at around half the tower height. (Fig. A3.06)
- All adjusting nuts (**1.4**) are to be turned until they touch the rubbing plates (**1.7**).
- For the crane lifting gear, scaffold tubes (**10.1**) are to be mounted under the frame tubes of the topmost frame. (Fig. A3.07)

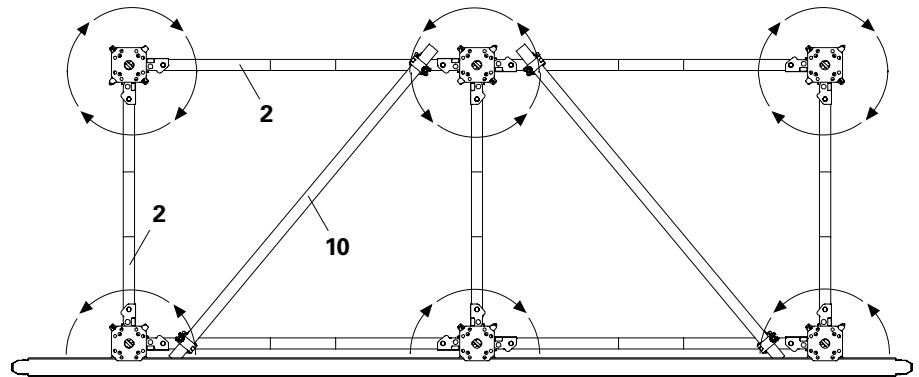

Fig. A3.06

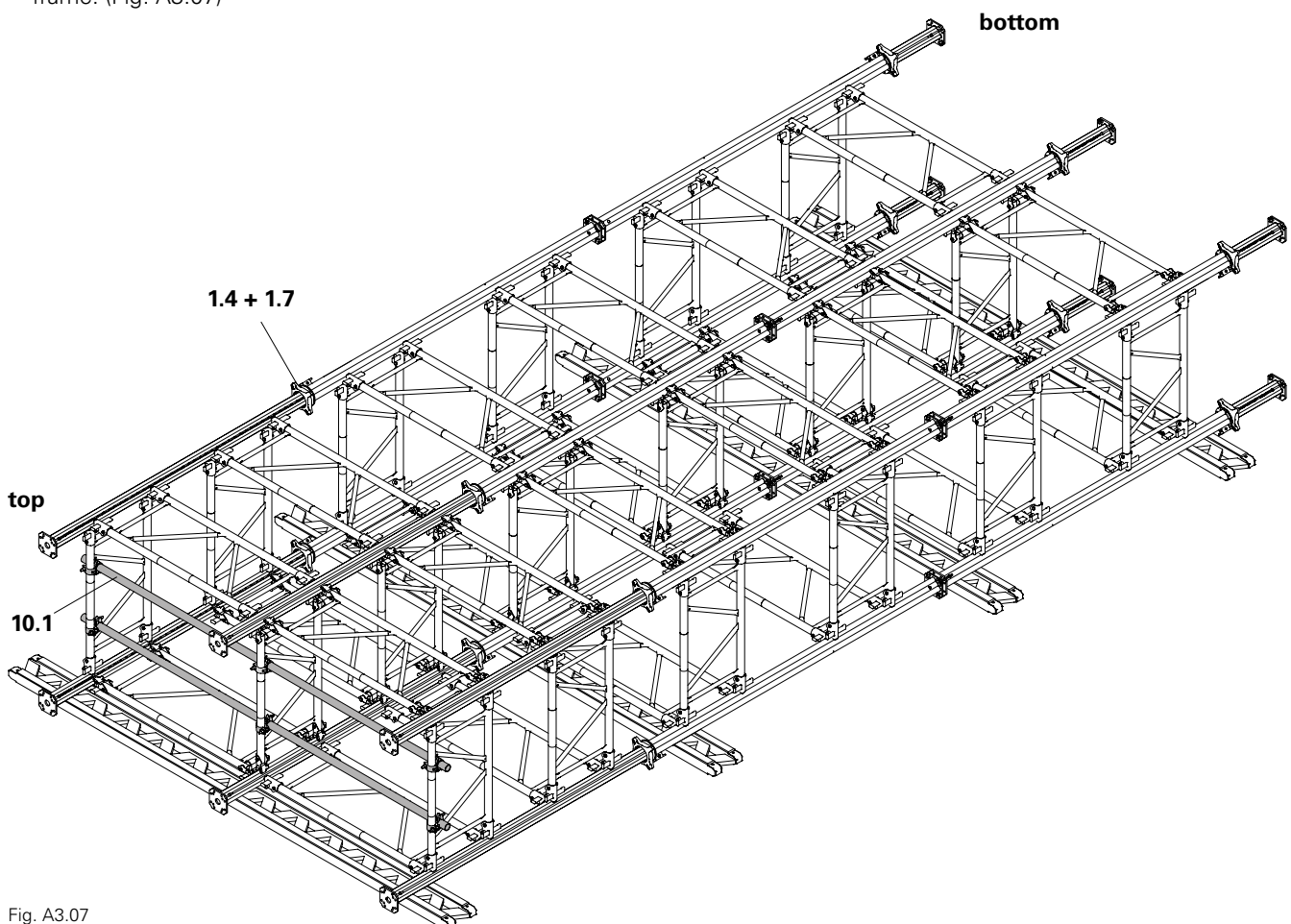

Fig. A3.07

Erecting the tower

Rectangular towers are erected via the shorter side of the frame and rotated around the longitudinal axis.

Rotating the tower around the longitudinal axis

1. Brace the tower in the centre with a horizontal brace, see Fig. A3.05.
2. With a 2-sling lifting gear, attach the tower on one side and symmetrically to the tower height. (Fig. A3.08)
3. Lift tower slightly.
4. Turn tower by 90° and set it down on timber base.

The shorter frame is at the top/bottom. (Fig. A3.09)

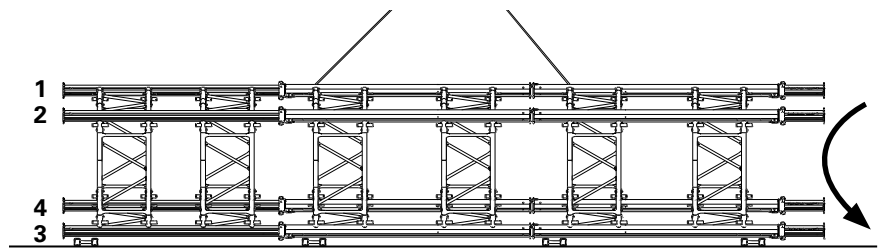

Fig. A3.08

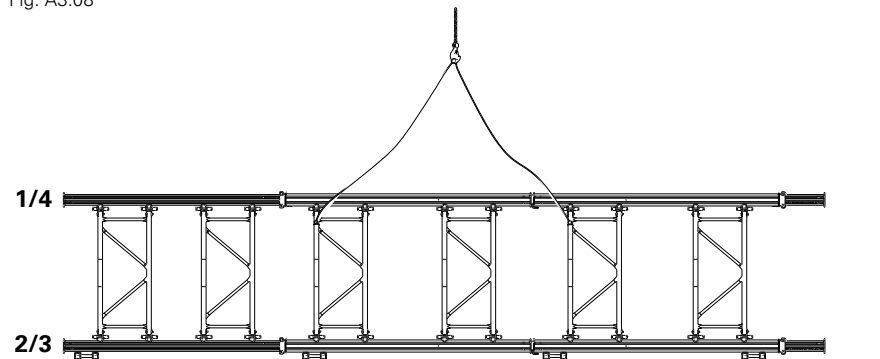

Fig. A3.09

Erecting the tower



Warning

- Heavy load on the crane!
 Tower can come loose and fall down.
 ⇒ Check wedges for tightness!
 ⇒ Do not stand under suspended loads.



- Before erecting, ensure that all adjusting nuts are resting against their respective rubbing plates. Securing hooks are closed.
- If necessary, secure tower with temporary mounting aids against tipping over, e.g. using Push-Pull Props, see A5.

Tower with 4 legs, with multiple number of legs

1. Mount push-pull prop connectors for the temporary mounting aid.
2. Completely insert the inner tubes (1.2) of the bottom props.
3. Extend inner tubes (1.2) of the top props. This prevents any large bending moments from developing and prevents the tower from impacting on the base plate with full force.
4. Attach slings: hook in 4-sling lifting gear (11) into two opposite frames of the topmost frame row or scaffold tubes. (Fig. A3.10 + A3.10a)
5. Erect tower and align.
6. Extend inner tubes (1.2) up to the required length and align so that the tower stands upright.
7. Install missing frames.
8. Secure tower against tipping over.
9. Detach lifting gear. (Fig. A3.11 - A3.11b)

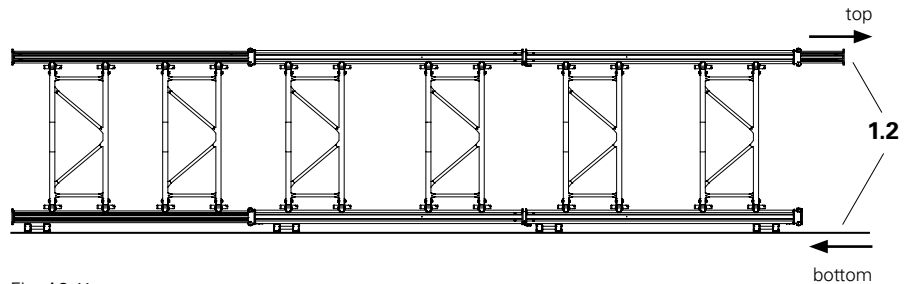

Fig. A3.11

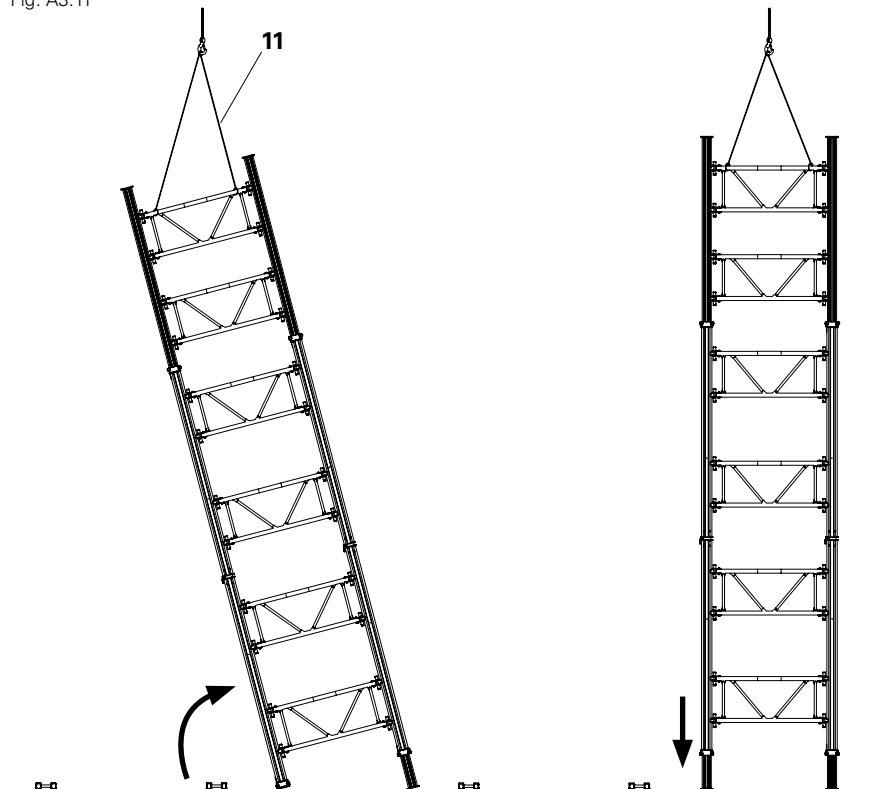

Fig. A3.11a

Fig. A3.11b

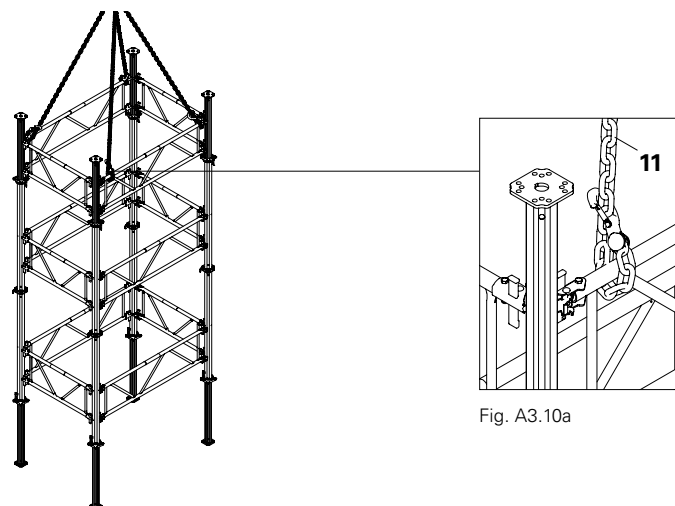

Fig. A3.10

Fig. A3.10a

First level

If horizontal assembly is not possible due to reasons of space or other circumstances, erection can take place vertically.



Secure props against tipping!

Preparation

1. Adjust lengths of MULTIPROP Props, see A1.
2. Ensure the required number of frames are available.

Assembly

1. Position MULTIPROP Props (**1**):
 - Use the Universal Tripod (**12**) as an erection aid.
 - Position props according to the dimension between axes of the frames to be assembled.
 - Inner tubes (**1.2**) are at the bottom.
 - The measuring scale (**1.6**) is pointing inwards. (Fig. A4.01)
2. Install Frames MRK, see A3:
 - e.g. use trestles, work scaffolds.
 - Place frames (**2**) at the designated positions, see plan or type test.
 - Securely fix the wedges (**2.3**) with a hammer blow from top to bottom. (Fig. A4.02)

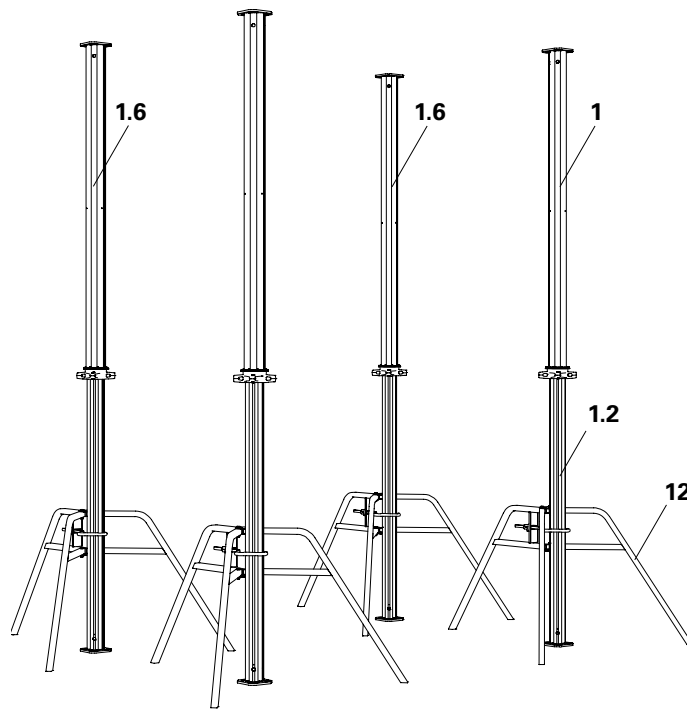

Fig. A4.01



The text on the adhesive label (**2.4**) is legible from the ground!

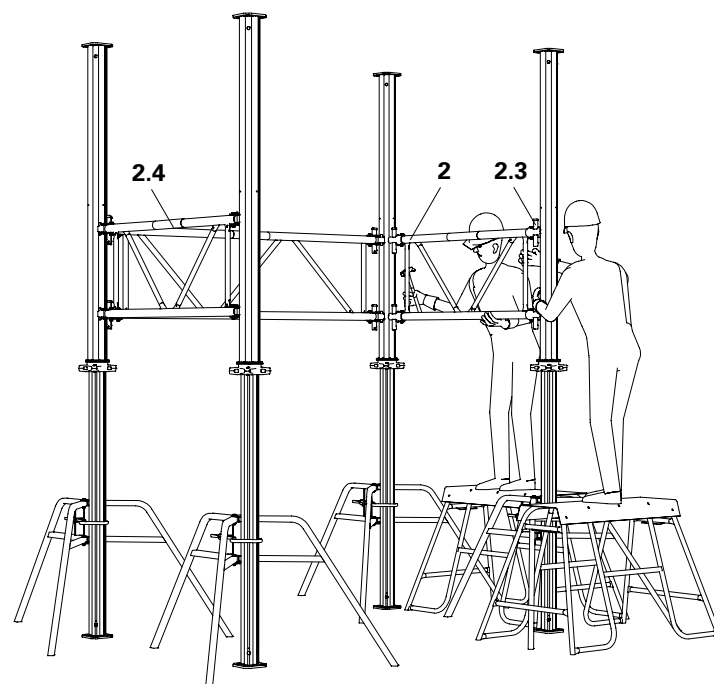

Fig. A4.02

Next level



- Check the stability!
- Use decking with anti-slip protection and sufficient load-bearing capacity as assembly platforms!
- Guardrail spacing for the assembly levels $e \leq 1.0$ m.
- Access, e.g. with PERI Telescopic Ladder Alu 220/350.

Assembly

- In order to mount the next prop and frame level, an assembly level (**16**) must be installed, e.g. MULTIPROP Decking. (Fig. A4.03)
- If necessary, temporarily secure tower against tipping over, see Section A5.

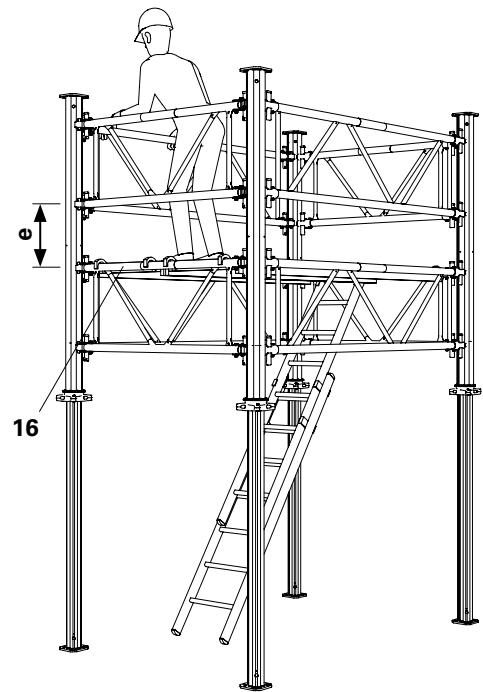

Fig. A4.03

Additional levels

Assemble additional levels in the same way.

Assembly

- Distance between the individual assembly levels in accordance with the risk assessment. Mount guardrails.
- Mount props with retracted inner tubes. Spindle out to the required length only after bracing has taken place with the frames. (Fig. A4.04)
- Connect props: with Connector MPV-2 or MULTIPROP Bolt with Nut, see A2.
- The frames can also be used as lateral guardrails and are to be additionally mounted if required.



Scaffold tubes with a diameter of 48 can also be used as temporary lateral guardrails; see Section B1. (Fig. A4.04a)

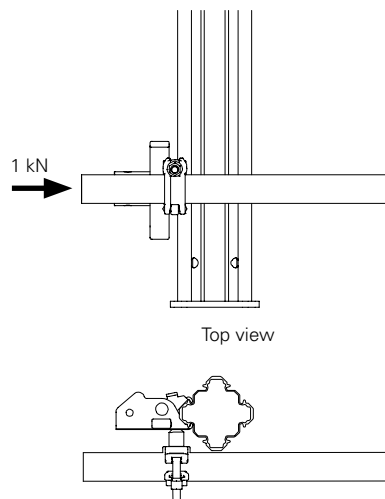

Fig. A4.04a

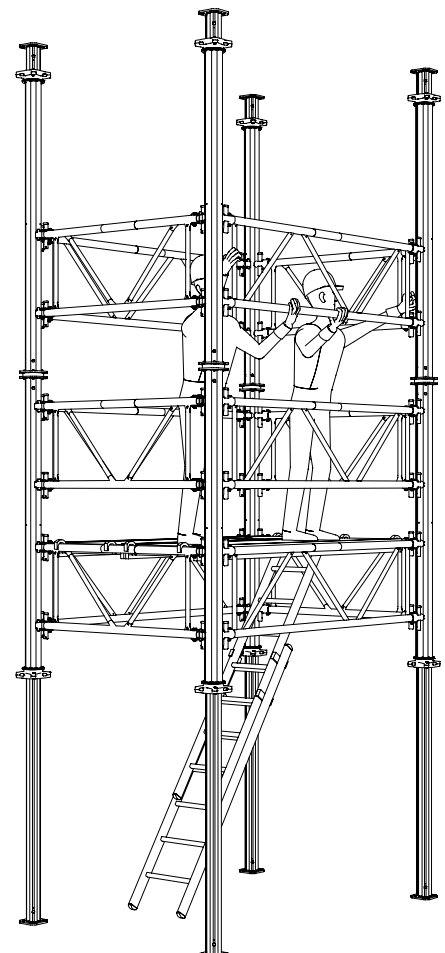

Fig. A4.04

Installing the Brace Connector MPR

The Brace Connector MPR can be assembled or disassembled temporarily. The Brace Connector MPR is assembled at the joints of the MULTIPROP Props. This applies equally to all prop arrangements (inner tube – inner tube, inner tube – outer tube, outer tube – outer tube).

The Brace Connector MPR can be used both on the direct connection with end plates and on the connection with Connector MPV.

Direct connection of the end plates



The end plate connection must be secured with 2 MULTIPROP Bolts (8)!

Assembly

1. Remove both Bolts (14) from the Brace Connector MPR (13).
2. Push Brace Connector MPR over both end plates.
3. Fasten with both Bolts and secure with Cotter Pins (14). (Fig. A5.01a)



If the Brace Connector MPR is to remain on the prop connection permanently, 1 MULTIPROP Bolt (8) on the side opposite the connection is sufficient. (Fig. A5.01b)

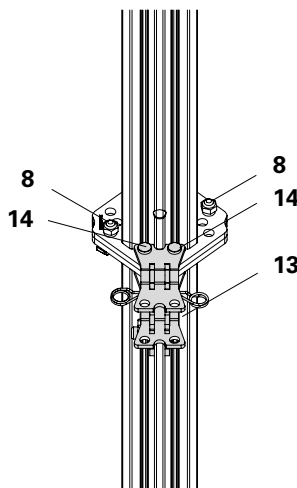

Fig. A5.01a

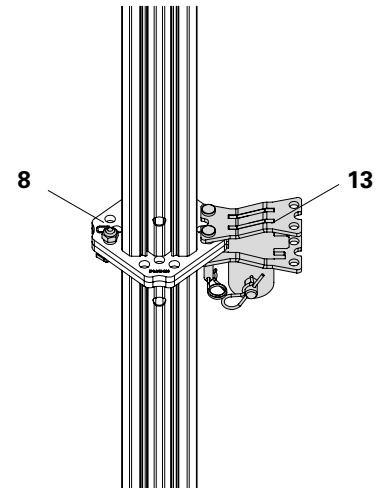

Fig. A5.01b

Connecting the end plates with Connector MPV-2

Assembly

1. Remove both Bolts (14) from the Brace Connector MPR (13).
2. Push the broader opening of the Brace Connector MPR over both end plates.
Not possible on the clamping lever (7.1).
3. Fasten with both Bolts and secure with Cotter Pins (14). (Fig. A5.01c)

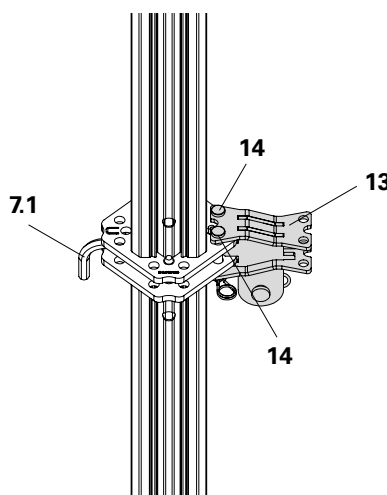
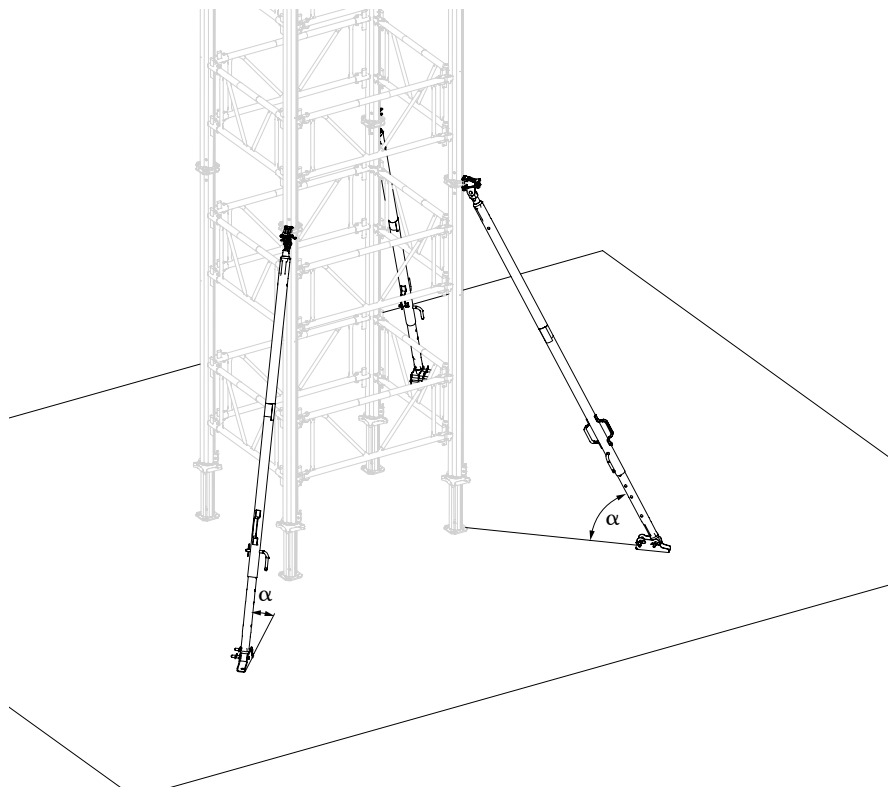

Fig. A5.01c

A5 Bracing MULTIPROP Towers

Permissible load of the Brace Connector MPR

Connecting the end plates	Angle α [°]	Perm. pressure [kN]	Perm. tensile force [kN]
direct	45	4.4	9.7
direct	60	9.1	9.9
with MPV-2	45	8.0	9.1
with MPV-2	60	11.9	12.1



Support with Push-Pull Props

During assembly and disassembly, the MULTIPROP Towers or units must be secured against tipping over using temporary assembly aids if necessary.



Warning

Risk of tower tipping!

Tipping of the tower can result in serious injury or even death.

- ⇒ Units have to support one another.
- ⇒ For providing stability, mount 3 Push-Pull Props as assembly aids.

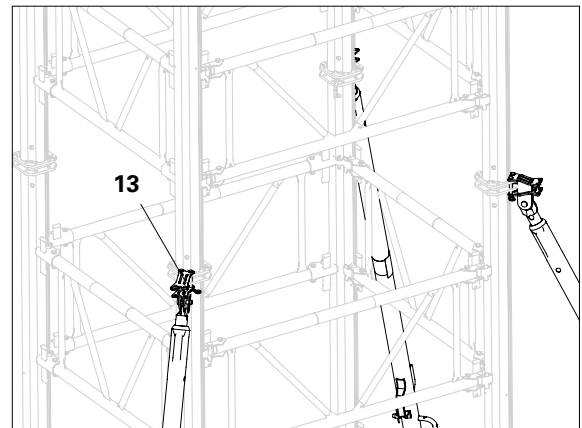

Fig. A5.02a

Assembly

1. Fix Brace Connector MPR (13) to prop joint. (Fig. A5.02a)
2. Fix Push-Pull Prop with bolts and cotter pins.
3. Fix Base Plate to the foundation by means of an anchor bolt.
4. Fix Push-Pull Prop to the base plate with bolts and cotter pins. (Fig. A5.02b)
5. Mount additional Push-Pull Props and detach tower from the crane. (Fig. A5.02)

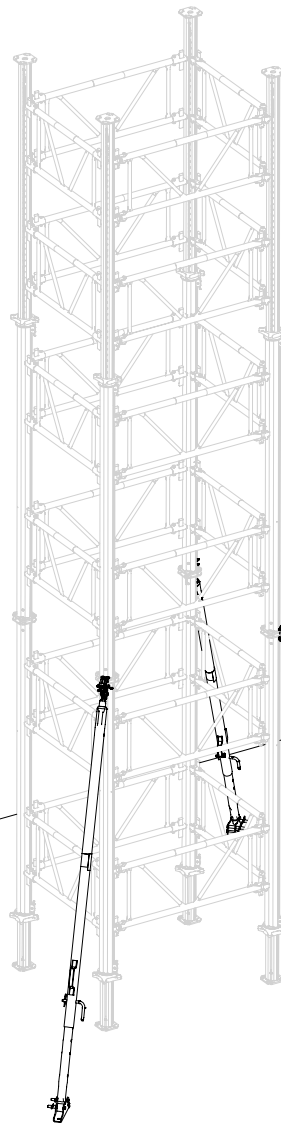

Fig. A5.02

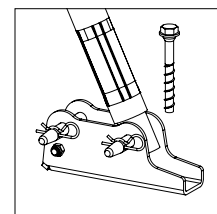

Fig. A5.02b

Supporting in units

Assembly

1. Arrange MULTIPROP Towers in the grid of the Frames MRK.
2. Install Frames MRK between the towers. (Fig. A5.03)
3. Hammer in wedges.
4. Install Push-Pull Props at the prop joints. (Fig. A5.03a)

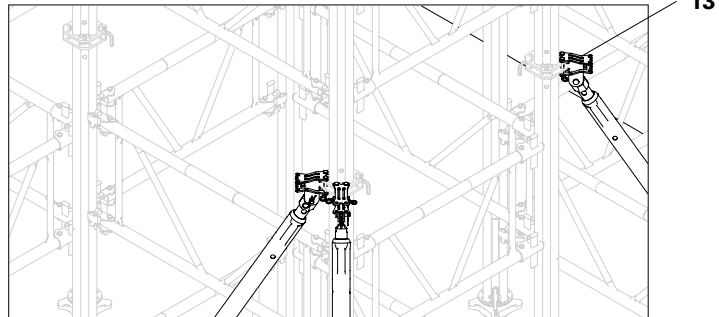

Fig. A5.03a

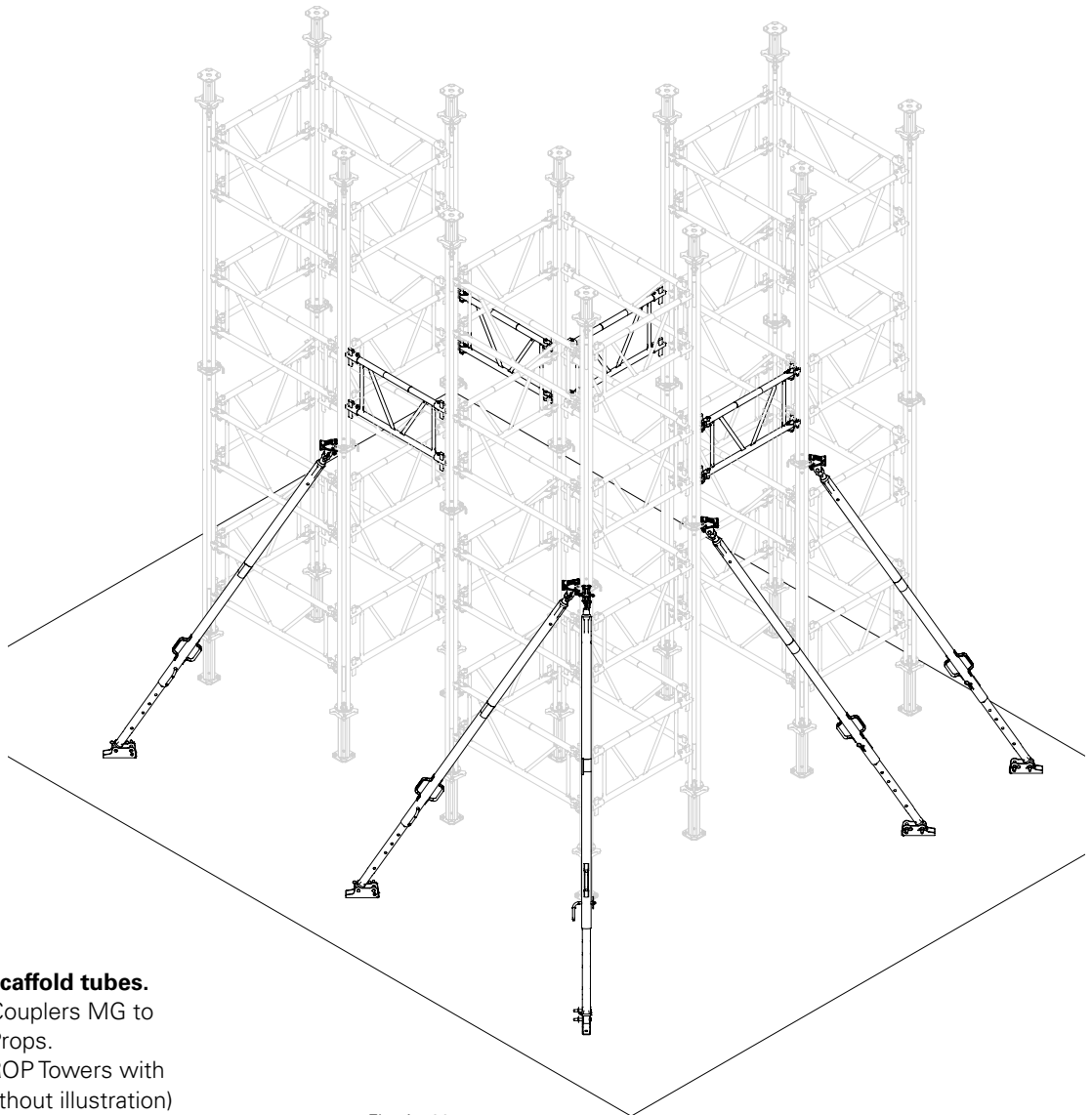

Fig. A5.03

Alternatively:

Connections with scaffold tubes.

1. Fix Scaffold Tube Couplers MG to the MULTIPROP Props.
2. Connect MULTIPROP Towers with scaffold tubes. (without illustration)

MULTIPROP Strap U100 – U140

In order to transfer high loads, during the assembly of a slab table, instead of twin main beams consisting of GT 24 Girders, Steel Walers SRU can also be connected to the props as the main beam. One MULTIPROP Strap U100 – U140 is assembled to each prop.

Assembly

1. Release Hex. Nut M16 (**6.4**).
2. Swivel Mounting Plates (**6.1**) outwards.
3. Guide the strap over the SRU Steel Waler from the top. (Fig. A6.01a)
4. Align the flange of the plate (**6.2**) between the webs of the steel waler.
5. Swivel the mounting plates (**6.1**) back and hook them into the bores of the base or head plate (**1.8 and 1.9**) from below.
6. Tighten Hex. Nuts M16. (Fig. A6.01b)

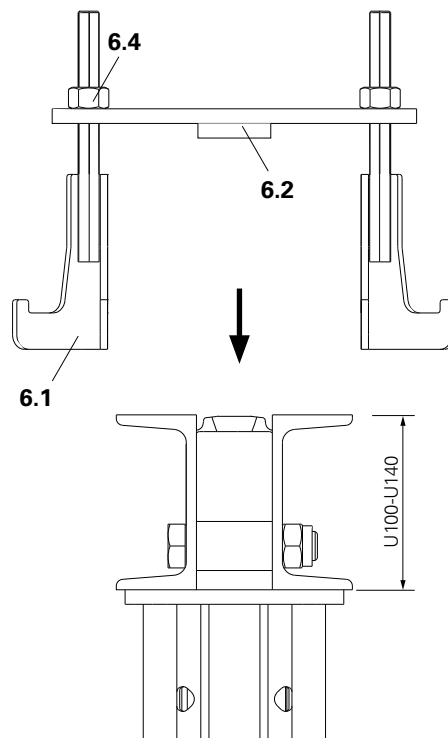

Fig. A6.01a

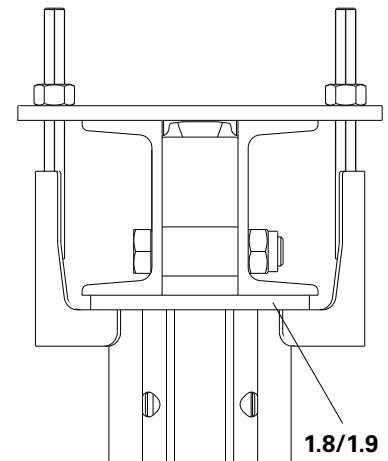

Fig. A6.01b

The strap holds the SRU Steel Waler in position on the prop.

Releasing

1. Release Hex. Nut M16 (**6.4**).
2. Remove mounting plates from the drilled holes of the base or head plate and remove strap.

Connecting MULTIPROP with MPB 24

For transferring high loads, the Aluminium Beam MPB 24 can be used as the main beam.

Assembly

Assembly takes place with two diagonally-arranged Straps MPB 24 (**6.5**) and MP Bolts with Nuts (**8**). (Fig. A6.02)

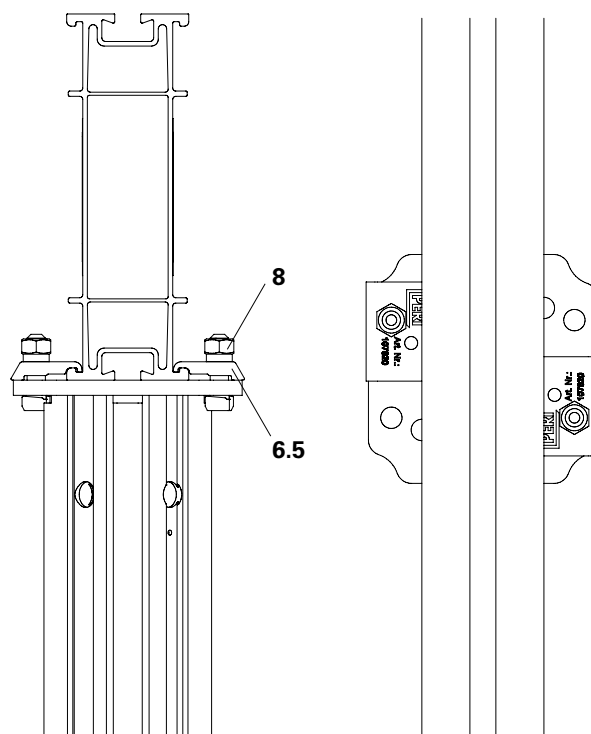

Fig. A6.02

Splice MPB 24

The Splice MPB 24 (**10**) connects multiple Aluminium Beams MPB 24 (**11**) to form a longer unit.

Permissible loads of the connection:

perm. **M** = 8.8 kNm

perm. **Q** = 23.5 kN



- If extended units are used as twin main beams, the bolts must point outwards. (Fig. A6.04 + A6.04a)
- When twin main beams are used, the Crosshead 20/24 S (Item no. 028680) is used on the MULTIPROP MP.
- The joints must be arranged at least 15 cm offset from one another. (Fig. A6.04)

Assembly

1. Position two Aluminium Beams MPB 24 (**11**) at the joint.
2. Insert the splice MPB 24 (**10**) (Fig. A6.03)
3. Insert in the 1st and 4th holes respectively with four bolts 20 x 140 (**12**), and secure with cotter pins (**12.1**). (Fig. A6.03a + A6.03b)

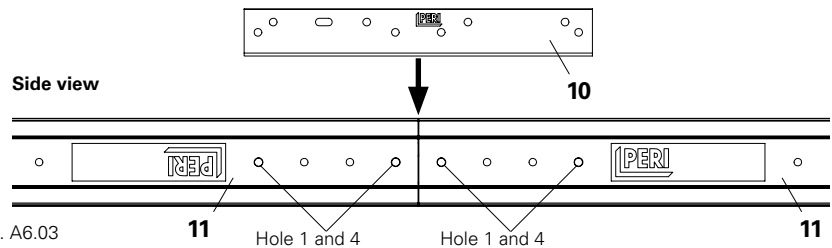

Fig. A6.03

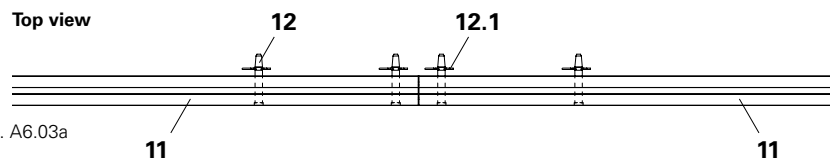

Fig. A6.03a

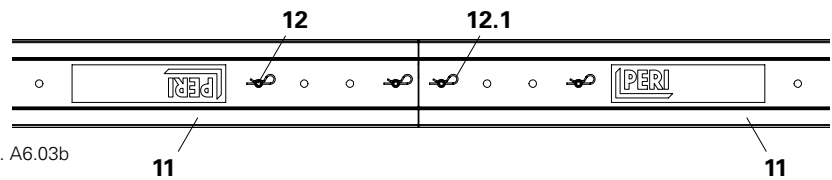

Fig. A6.03b

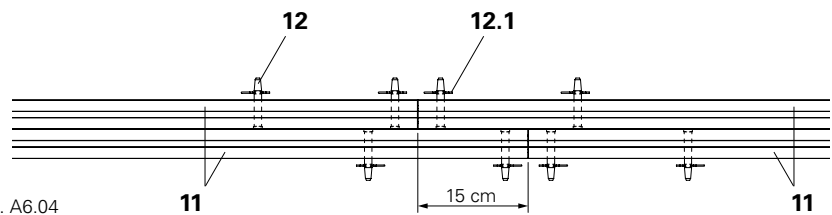

Fig. A6.04

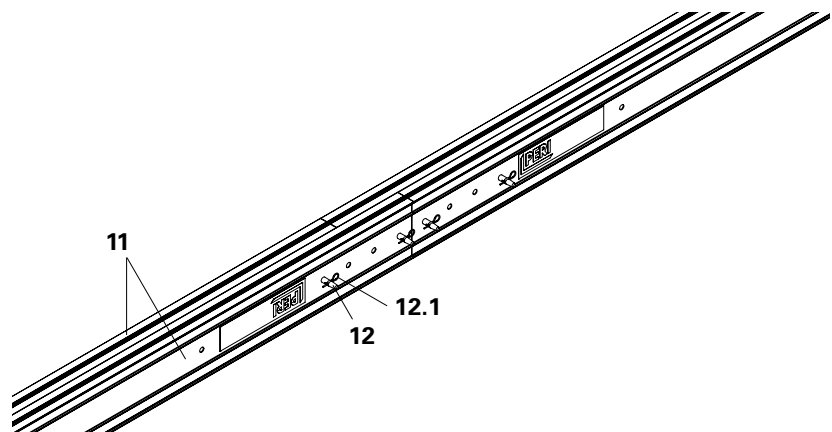

Fig. A6.04a

Dismantling

Horizontal dismantling is preferred. Vertical dismantling, however, is possible.



- Ensure stability during dismantling!
- Avoid load concentrations by lowering the props evenly!
- Use Wing Nut Spanner HD to release loads > 60 kN!
- Rotation direction when lowering: Detachment is in the direction of the arrow on the adjusting nut.

Vertical dismantling

1. Temporarily secure tower against tipping over, see Section A5.
2. Release adjusting nut and set load free by:
 - hammering lowering cam (Fig. A7.01a)
 - using Wing Nut Spanner HD Item no. 022027 (Fig. A7.01b)
 - permissible impact force
3. Lower the MULTIPROP Tower.
4. Remove formwork assembly.
5. Dismantle tower from top to bottom. Remove horizontal assembly bracing only when stability has been ensured. (Fig. A7.01)



The Wing Nut Spanner HD facilitates energy-saving and noiseless loosening of the adjusting nut – even if the props are placed under maximum load. Max. $F = 0.95 \text{ kN}$.

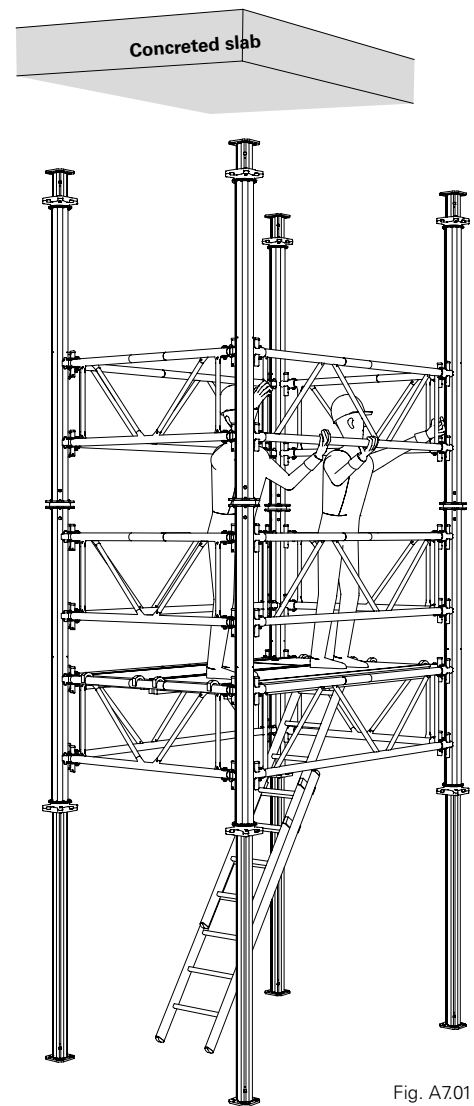

Fig. A7.01

Outer tube bottom

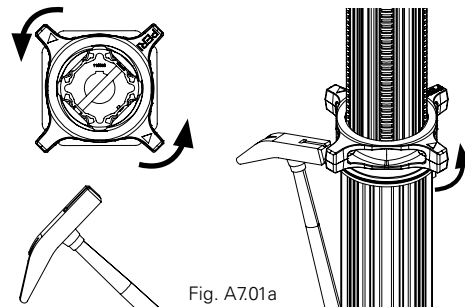

Fig. A7.01a

Outer tube bottom

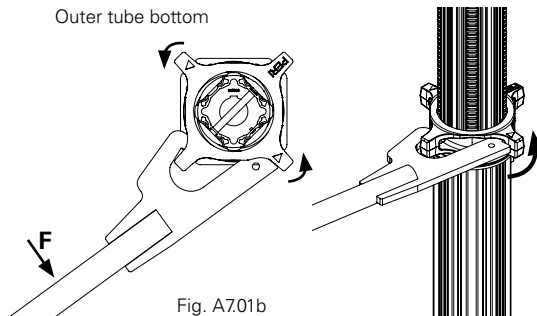

Fig. A7.01b

Horizontal dismantling

1. Move the lowered MULTIPROP Tower out from underneath the concreted slab.
2. Attach crane lifting gear.
3. Slide in inner tubes on one side, see Section A3 With multiple number of legs.
4. Set down MULTIPROP Tower on level ground. (Fig. A7.02)
5. Dismantle the MULTIPROP Tower.



- If structural bracing has been installed, it is sensible to lower the MP Towers on the uppermost props.
- The Wing Nut Spanner HD facilitates energy-saving, noiseless and material-friendly loosening of the adjusting nuts – even if the props are placed under maximum load.

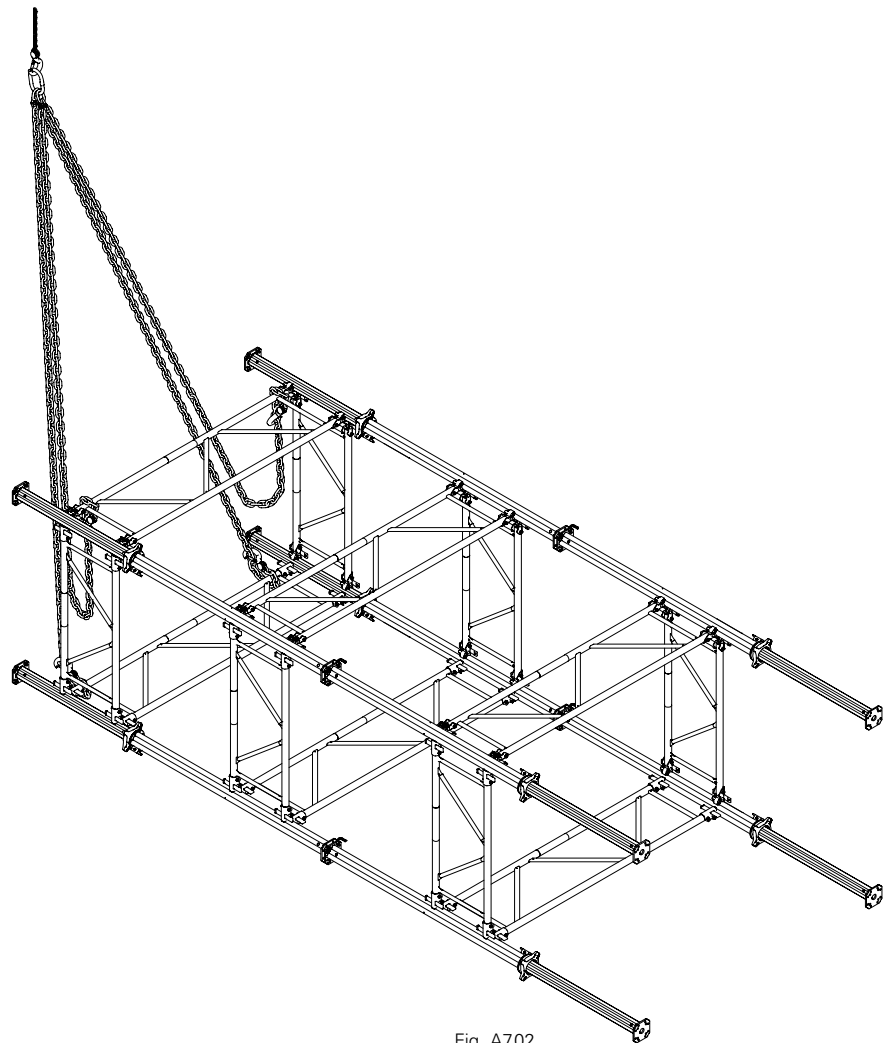

Fig. A7.02



- The Instructions for Use for PERI Pallets and Stacking Devices must be observed!
- Transportation units must be correctly stacked and secured!



The securing hook (1.3) prevents the inner tube (1.2) from slipping out and must be engaged.

Transportation

PERI pallets and stacking devices are suitable for lifting by crane or forklift. They can also be moved with the PERI pallet lifting trolley.

All pallets and stacking devices can be lifted using both the longitudinal and front sides.

The following are just some examples:
 MULTIPROP Slab Props with timber and steel strapping. (Fig. A8.02)
 MULTIPROP Frame MRK with steel strapping. (Fig. A8.04)

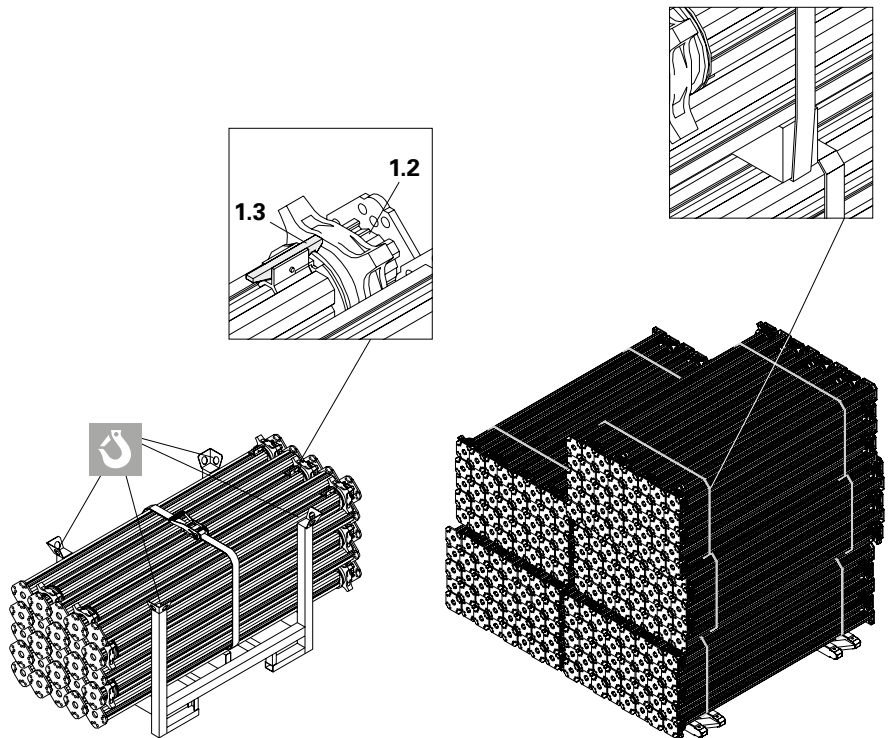

Fig. A8.01

Fig. A8.02

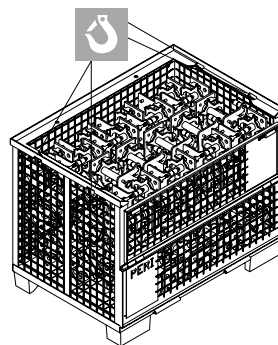

Fig. A8.03

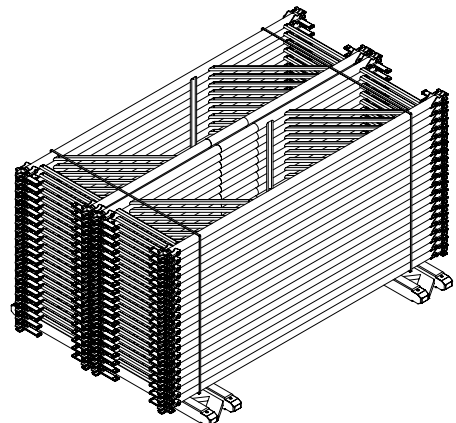

Fig. A8.04

Scaffold Tube Coupling MG



Check tilt resistance!

Horizontal scaffold tube bracing may be used as an assembly aid. They consist of Scaffold Tubes \varnothing 48 mm (**10**) and MULTIPROP Scaffold Tube Couplers MG-A / C or MG-B / D (**15**). The bracing is installed in segments and towers, and is designed to stabilise the MP Props. (Fig. B1.01)

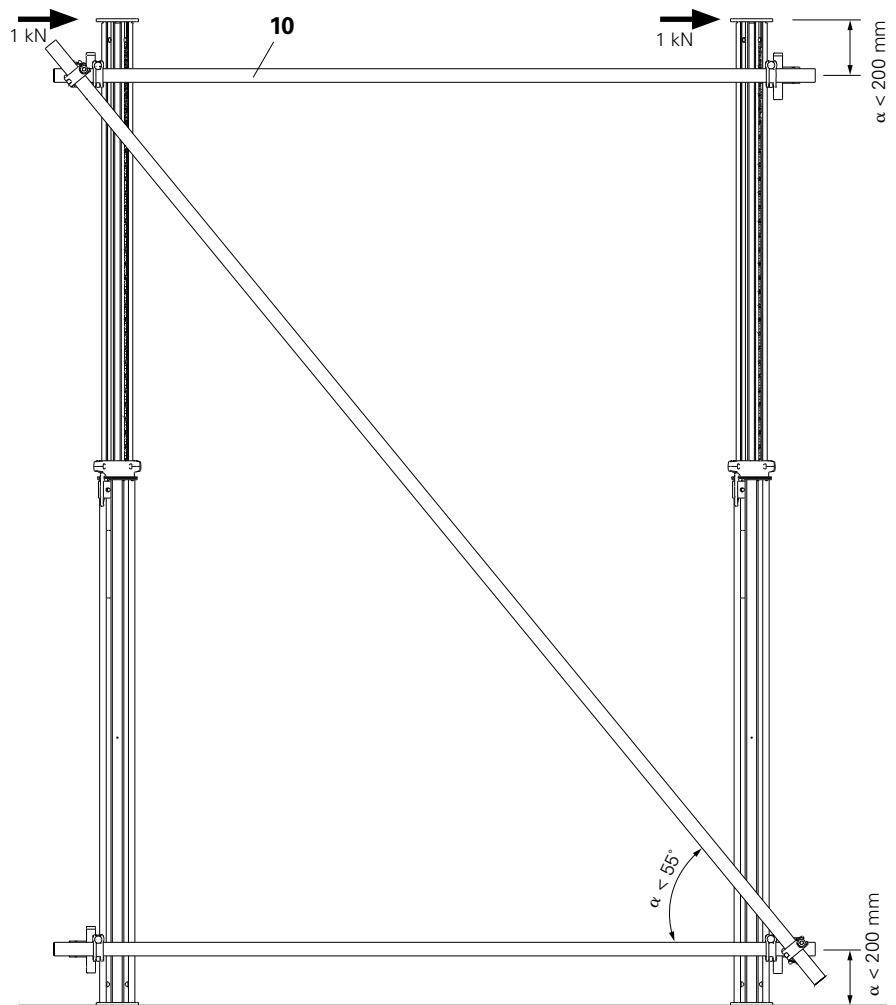

Fig. B1.01

Application 1:

Scaffold Tube Coupling MG for structural connection of MULTIPROP Props with scaffold tubes.

Requirements:

1. $\alpha < 200$ mm
2. $\alpha < 55^\circ$
3. Arrangement of the couplers, see Fig. B1.02a.

The bracing can carry a horizontal force of $F_H = 1 \text{ kN} + 1 \text{ kN} = 2 \text{ kN}$.

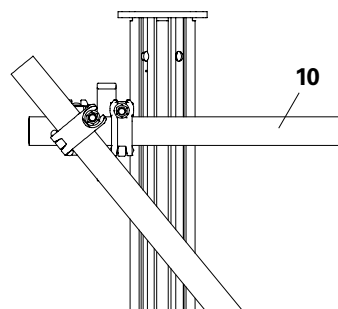
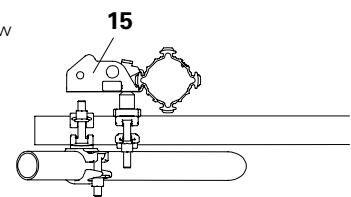

Fig. B1.02a

Top view



Application 2:

Scaffold Tube Coupling MG for transferring small horizontal forces.

A force F_H of 1 kN can be transferred along a horizontal scaffold tube. (Fig. B1.02b)

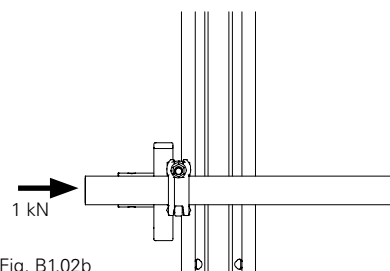
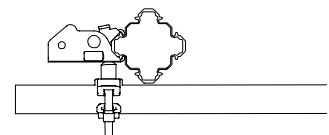

Fig. B1.02b

Top view



Use as scaffold girder



The decking can fall down under heavy loads.
A fall can result in serious injury or even death.
⇒ Check wedges for tightness!
⇒ Do not use frames smaller than MRK 120 as girder support!

As assembly or working platform, decks can be inserted at one frame level. (Fig. B2.01) The use of MULTIPROP Decking with/without hatch is recommended as well as the Telescopic Ladder Alu 220 / 350. The assembly of the frames is carried out as described in A1.



If MRK frames are used as girder support, they must be mounted on the outer tubes of the props.

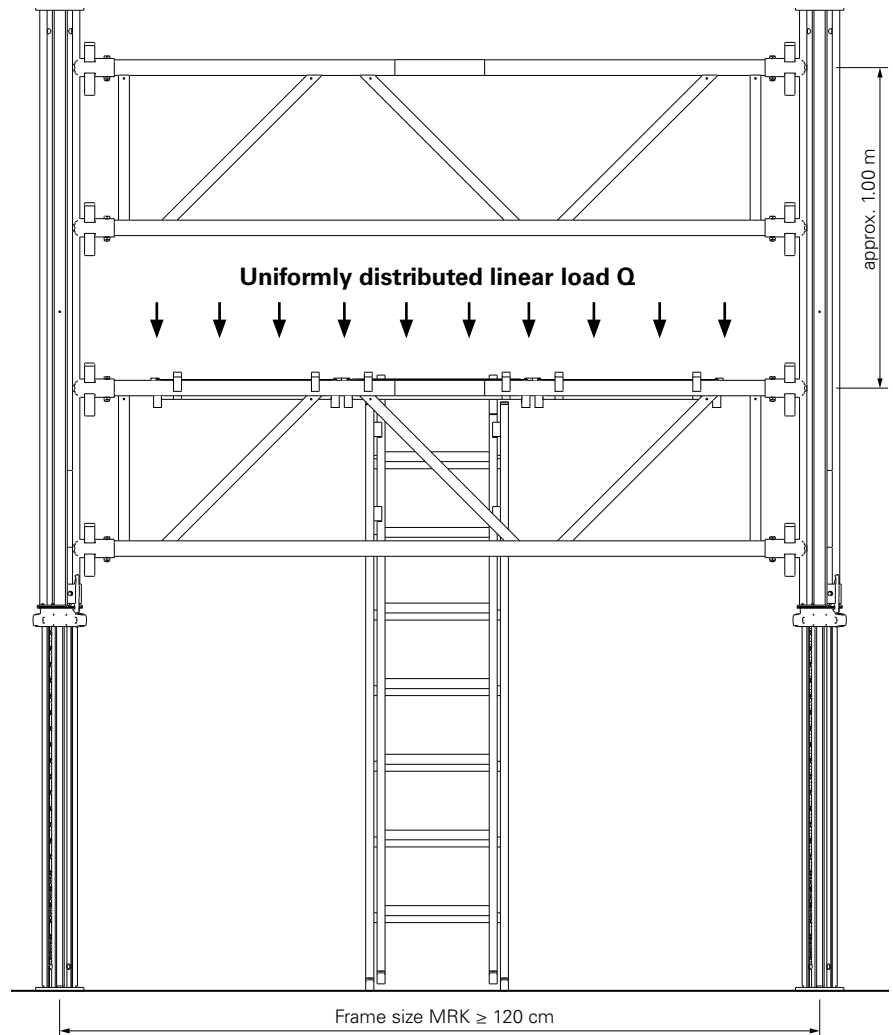

Fig. B2.01

Table
Permissible loads for the Frames
MRK as scaffold girders.

Frame size	Perm. uniformly distributed linear load Q [kN/m]
MRK 350	0.8
MRK 296	1.1
MRK 266	1.4
MRK 237	1.8
MRK 230	1.9
MRK 225	2.0
MRK 201.5	2.6
MRK 150	4.0
MRK 137.5	4.4
MRK 120	5.0

Lowering



- Check stability!
- The lowering process must be divided into small, brief lowering steps. The lowering process must be performed on all props simultaneously in order to prevent overloading of the props or inclinations of the table.

1. Turn adjusting nut (1.4) of the MULTIPROP Prop and fit inner tube (1.2).
2. Repeat the process for all props.



Frame to inner tube: Release wedges at two positions that are diagonally opposite. (Fig. B3.01a)



In order to make the lowering procedure easier, the table or tower can be held in position by the trolley and winch unit or the trolley. The props can be spindled in without being subjected to any load. (Fig. B3.01)

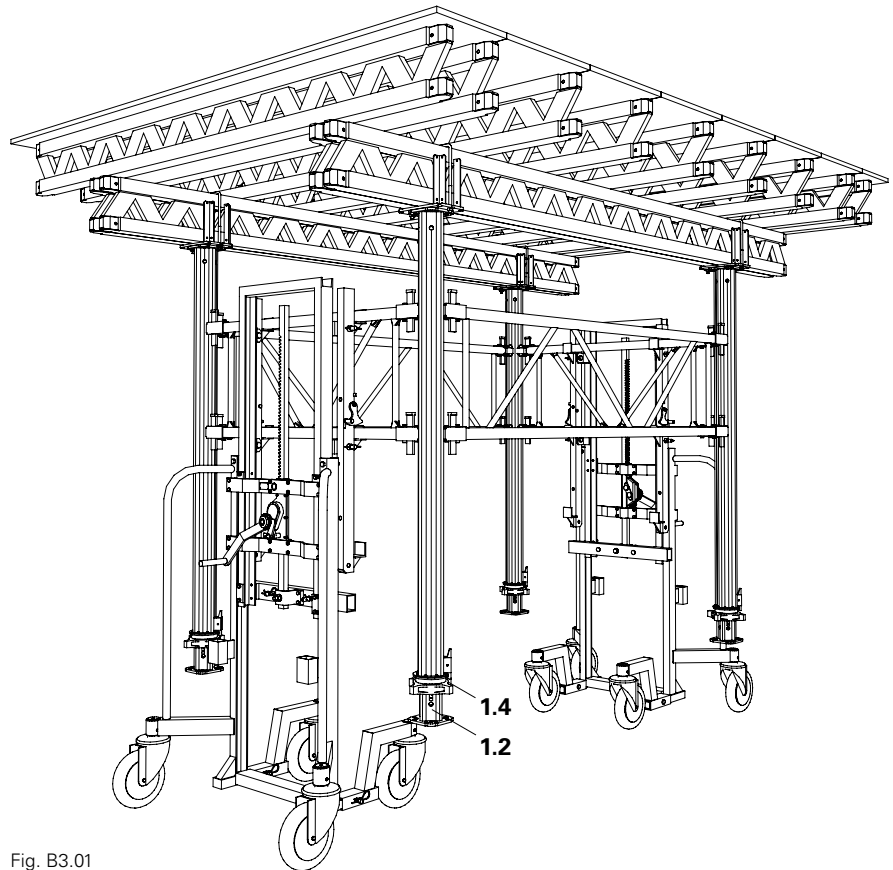

Fig. B3.01

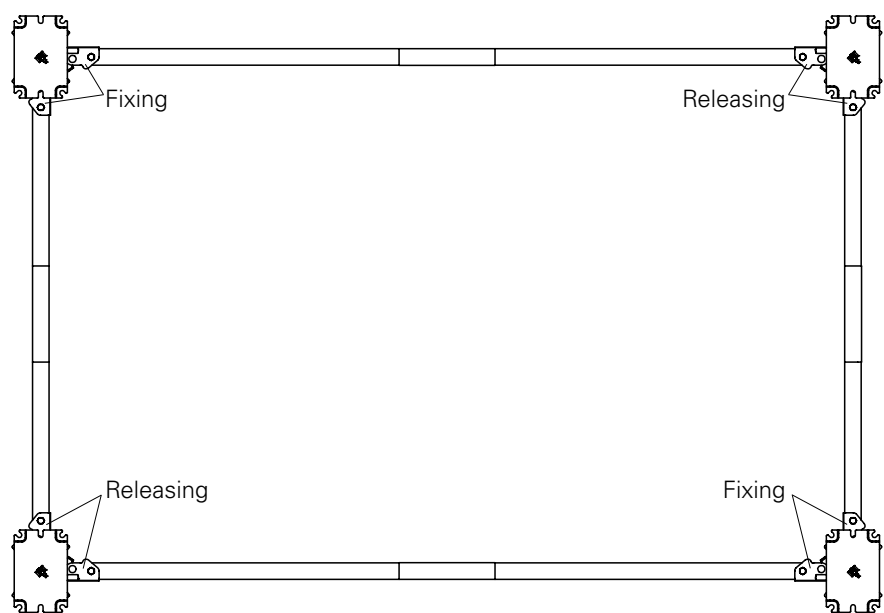

Fig. B3.01a

Moving with the Trolley and Winch Unit



Observe the Instructions for Use for the PERI Trolley and Winch Unit! Moving unit can tip over!

Moving

1. Position two Trolley and Winch Units in the centre of the narrow frame sides of the shoring for each table or tower.
2. Support the frames using the MULTIPROP Adapters.
3. Uniformly raise the table or tower with the winches.
4. Move the table or tower.

Permissible weights and heights

Requirements for process in longitudinal direction

MULTIPROP \geq MRK 137.5

Total weight Tower / Table	Direction of travel longitudinal Table height up to	Direction of travel transverse Table height up to
0 – 300 kg	600 cm	600 cm
301 – 400 kg	700 cm	650 cm
401 – 500 kg	800 cm	700 cm
501 – 600 kg	800 cm	700 cm
601 – 800 kg	800 cm	650 cm
801 – 1,000 kg	750 cm	600 cm
1,001 – 1,200 kg	700 cm	550 cm
1,201 – 1,400 kg	650 cm	550 cm
1,401 – 1,600 kg	650 cm	500 cm
1,601 – 2,000 kg	600 cm	500 cm

MULTIPROP

Permissible Frame MRK for tables and towers

Aluminium frame	Perm. lifting capacity [kg]	Steel frame	Perm. lifting capacity [kg]
MRK 350	280	MRK 150	880
MRK 296	350	MRK 137.5	920
MRK 266 – 225	440		
MRK 201.5	560		

Moving along with pole

In order to bring the slab table into the exact position, the PERI MULTIPROP Table can be moved by means of a reinforcing bar and a pole.

Moving

1. Insert reinforcing bar (**16**) into the bottom holes of the MULTIPROP Props.
2. Move the slab table with the reinforcing bar \varnothing 16 mm (corresponding foot hole) or pole (**17**). (Fig. B3.02)

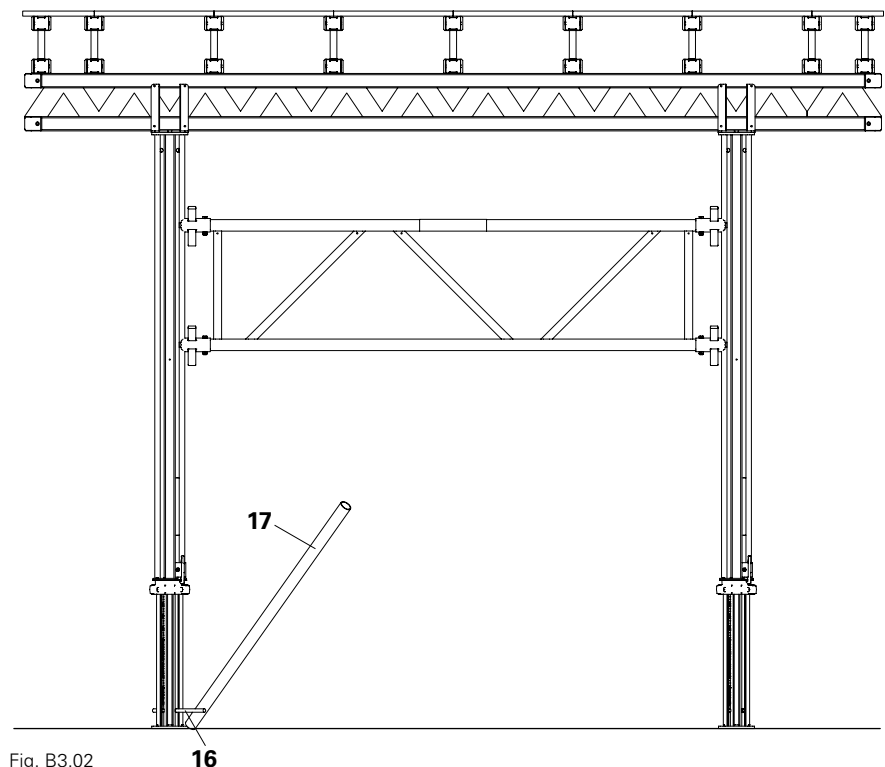

Fig. B3.02

16

Tables

The load-bearing capacity of the shoring towers in the MULTIPROP system is dependent on the position of the MRK bracing frames.

The values are exclusively available in the relevant current version of the type test.

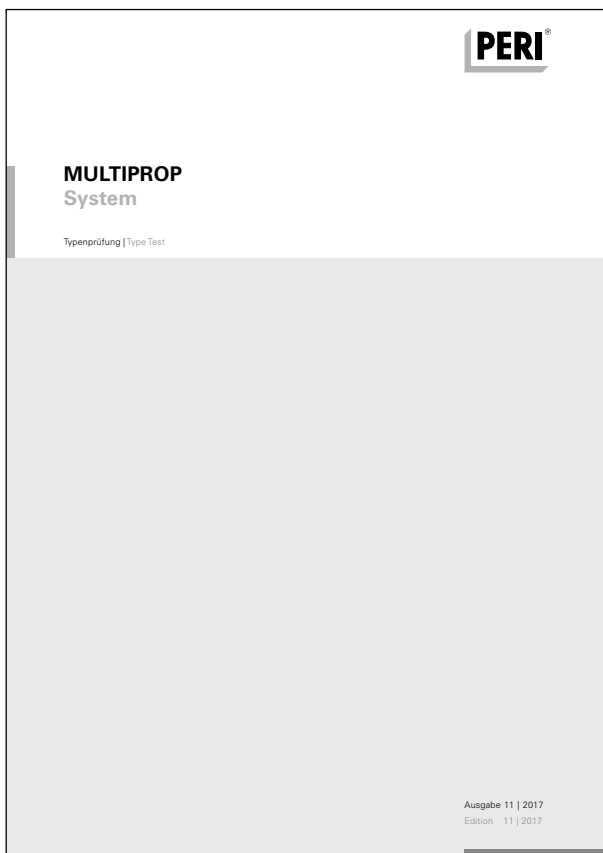

Item. no. Weight kg

027288	10.100	MULTIPROP MP
027289	15.400	MULTIPROP MP 120
027290	19.400	MULTIPROP MP 250
027291	24.700	MULTIPROP MP 350
027305	34.500	MULTIPROP MP 480
		MULTIPROP MP 625

Slab prop made of aluminium. To be used as an individual prop, or in combination with MULTIPROP Frames MRK as a tower.

min. L	max. L
800	1,200
1,450	2,500
1,950	3,500
2,600	4,800
4,300	6,250

Technical data

See PERI Design Tables for permissible load.

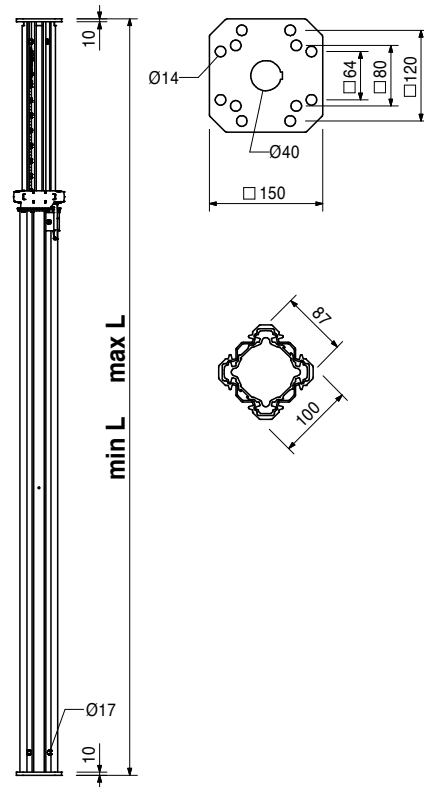
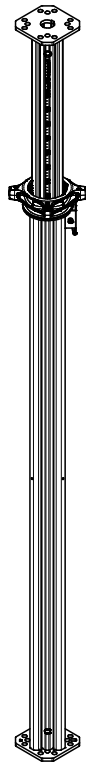

		MULTIPROP Frame MRK, steel
028390	9.860	Frame MRK 62.5
028400	10.100	Frame MRK 75
028330	11.300	Frame MRK 90
028340	14.000	Frame MRK 120
028380	15.400	Frame MRK 137.5
028350	16.300	Frame MRK 150

Bracing frame for MULTIPROP.
For connection to outer and inner tube.
With captive wedge lock.

L	X
545	625
670	750
820	900
1,120	1,200
1,295	1,375
1,420	1,500

Note

L = Loading dimension
X = Axial dimension

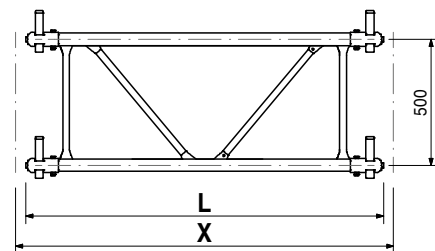
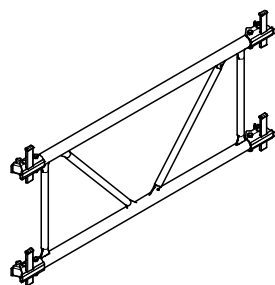

Item. no. Weight kg

Item. no.	Weight kg	MULTIPROP Frame MRK, aluminium
028460	11.600	Frame MRK 201.5
112719	11.900	Frame MRK 210
028360	12.400	Frame MRK 225
028470	12.500	Frame MRK 230
028480	12.800	Frame MRK 237
028490	14.000	Frame MRK 266
028370	14.900	Frame MRK 296
117358	17.000	Frame MRK 350

Bracing frame for MULTIPROP.
For connection to outer and inner tube.
With captive wedge lock.

L	X
1,935	2,015
2,020	2,100
2,170	2,250
2,220	2,300
2,290	2,370
2,580	2,660
2,880	2,960
3,420	3,500

Note
L = Loading dimension
X = Axial dimension

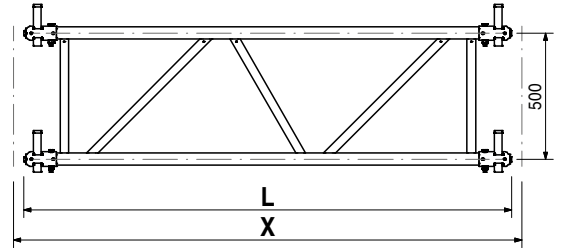
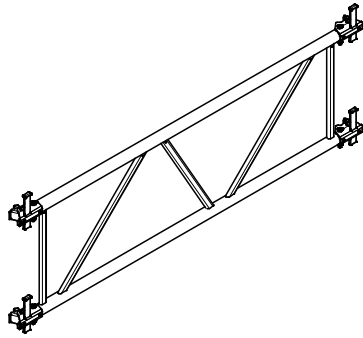

107169	12.000	MULTIPROP Decking MULTIPROP Deck 150 x 60
107170	18.000	MULTIPROP Deck 225 x 60

Decking unit for installation on MP frames.

Technical data
Permissible load 2.0 kN/m².

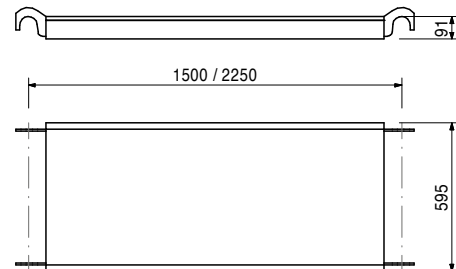
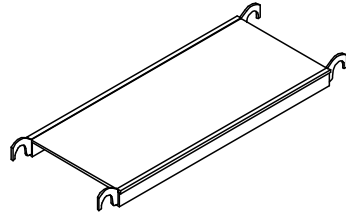

107171	12.500	MULTIPROP Decking with Hatch MULTIPROP Deck 150 x 60 with Hatch
107172	18.500	MULTIPROP Deck 225 x 60 with Hatch

Decking unit for installation on MP frames.
With self-closing hatch for ladder ascents.

Technical data
Permissible load 2.0 kN/m².

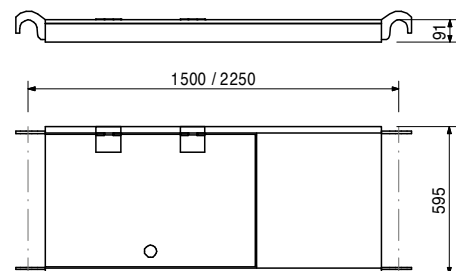
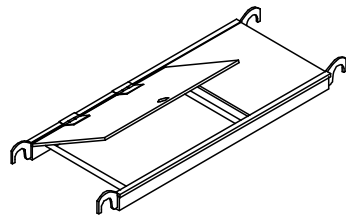

Item. no.	Weight kg
107173	9.000

Ladder Alu 220/350

For access at MULTIPROP towers. To be mounted to the deck with hatch.

Technical data

Extension length 2.20 – 3.50 m.

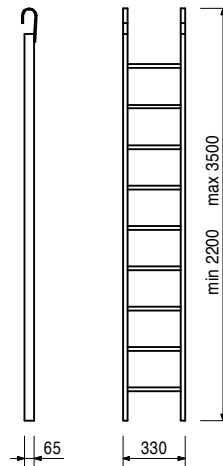
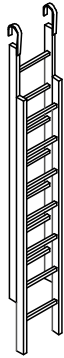

022027	3.600
--------	-------

Wing Nut Spanner HD

For easy removal of Head Spindle HDK 45, Head Spindle TR 110 - 80 / 55 and the MULTIPROP Slab Prop.

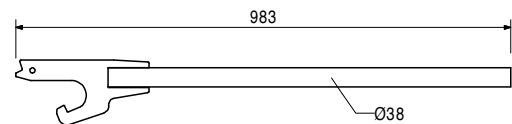
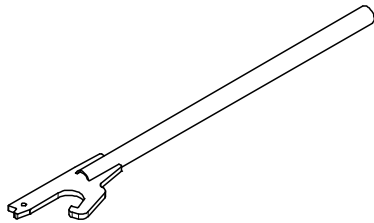

027310	8.900
--------	-------

Base MP 50

For use with props with 6 – 10 mm thick end plates. With quick-action clamp coupling.

Note

See PERI Design Tables for permissible load.

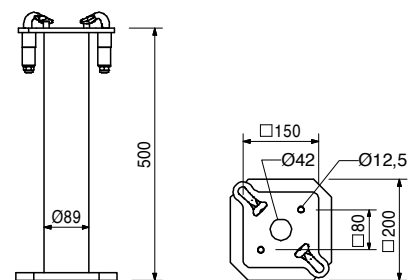
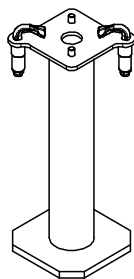

Item. no.	Weight kg
027297	8.730

Tilting Forkhead MKK

Providing stable support for one or two GT 24 or VT 20 girders. Tilting in any direction by 3°. With quick-action clamp coupling.

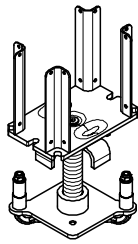

Note

Separate design information on request.

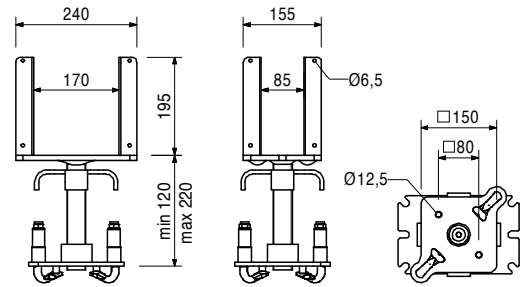

028680	3.190
--------	-------

Crosshead 20/24 S, galv.

With or without self-locking coupling. Providing stable support for one or two GT 24 or VT 20 girders.

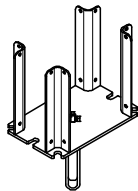

Note

Required bore diameter of prop end plate Ø 40 mm. Girder overlap on both sides at least 16.3 cm for GT 24 and 15 cm for VT 20.

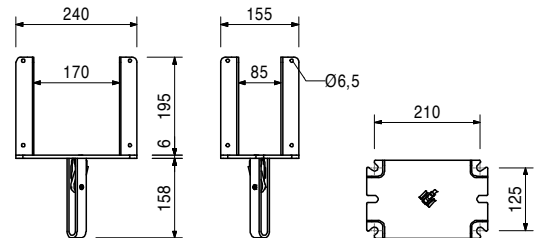

027296	6.220
--------	-------

Tilting Base MKF

For use with sloping ground slabs. Tilting in any direction by 3°. With quick-action clamp coupling.

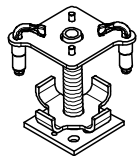

Technical data

Permissible load-bearing capacity 60 kN.

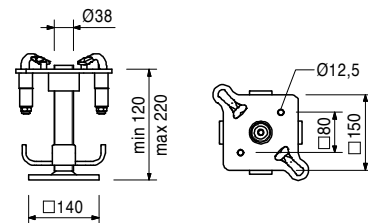

027298	2.200
027299	2.200

Scaffold Tube Connector Scaffold Tube Connector MG-A/C Scaffold Tube Connector MG-B/D

For mounting scaffold tubes Ø 48 mm on the MULTIPROP MP slab prop.

Note

Coupling not rotatable.

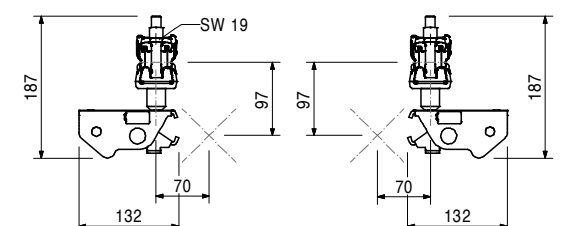
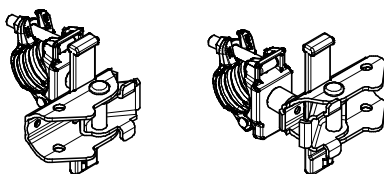

Item. no. Weight kg

028000 9.190

Universal Tripod 57 - 120

Assembly aid for slab props \varnothing 57 – 120 mm and 120 x 120 mm.
Can also be used in combination with MULTIPROP MP Slab Props and all slab props with Base MP 50.

Note

Use only as an assembly aid!

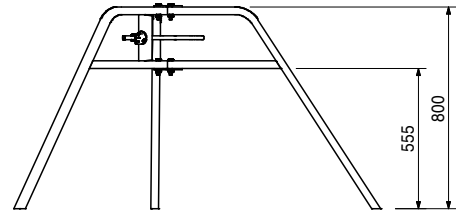
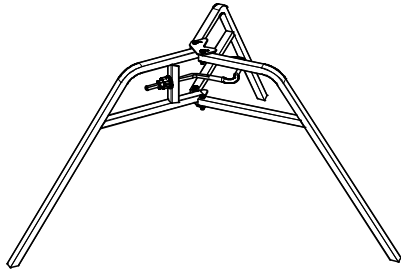

027301 1.030

Connector MPV-2

For connecting 2 MULTIPROP Slab Props.

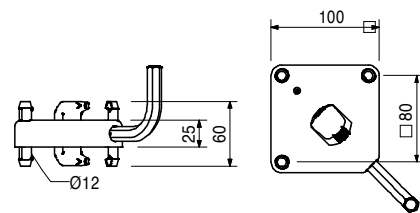
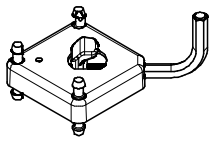

111142 0.082

MULTIPROP Bolt with Nut

For connecting 2 MULTIPROP MP Slab Props, the Push Prop Head MP/SRU and for assembly of accessories on Aluminium Beam MPB 24.

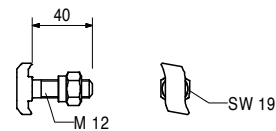

027302 2.100

MULTIPROP Strap U100 – U140

For mounting Steel Walers SRZ and SRU, profile U100 - U140 to MULTIPROP Slab Props.

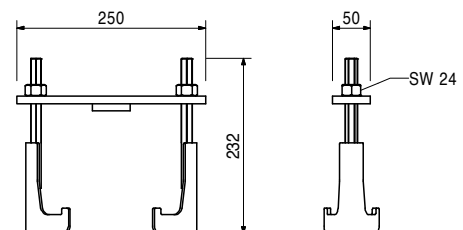
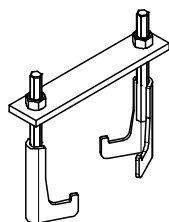

Item. no.	Weight kg
129565	1.680

Brace Connector MPR

For connecting Push-Pull Props in the MP system.

Complete with

- 1 pc. 027170 bolts \varnothing 16 x 42, galv.
- 1 pc. 018060 cotter pin 4/1, galv.
- 2 pc. 129560 collar stud \varnothing 12
- 2 pc. 127322 cotter pin 3, 2/2, galv.

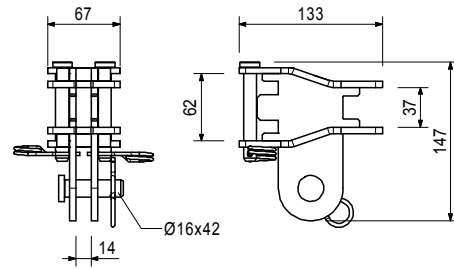
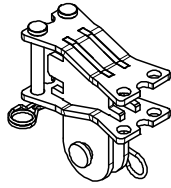

107161	3.050
--------	-------

Push Prop Head MP/SRU

Connecting element between MULTIPROP Slab Props and Steel Waler SRU/SRZ.

Note

Separate design information on request.

Technical data

Permissible load-bearing capacity 70 kN.

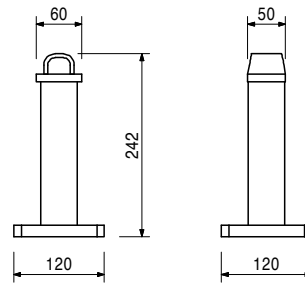
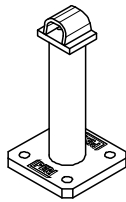

Accessories

104031	0.462
018060	0.014
111142	0.082

Fitting pin \varnothing 21 x 120

Cotter pin 4/1, galv.

MULTIPROP Bolt with Nut

107160	3.960
--------	-------

Connector MP/SRU

To provide compensation between Push Prop Head MP/SRU and inclined Steel Waler SRU.

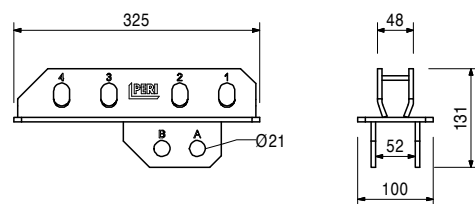
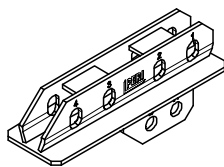

Accessories

104031	0.462
018060	0.014

Fitting pin \varnothing 21 x 120

Cotter pin 4/1, galv.

Item. no.	Weight kg
104031	0.462

Fitting pin Ø 21 x 120
For diverse connections.

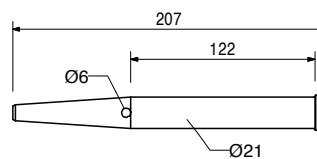
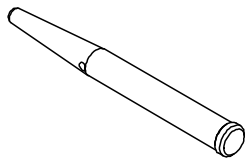

018060	0.014
--------	-------

Accessories
Cotter pin 4/1, galv.

105400	0.330
--------	-------

Pin Ø 20 x 140, galv.
For diverse connections.

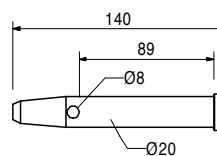
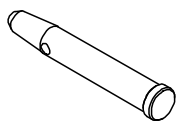

018060	0.014
--------	-------

Accessories
Cotter pin 4/1, galv.

018060	0.014
--------	-------

Cotter pin 4/1, galv.



Item. no.	Weight kg
019200	162.000

Trolley and Winch Unit

For moving towers and tables with MULTIPROP, PERI UP Flex, PERI UP Flex Plus, PERI UP Flex MDS K and PD 8 with respective support for the system.

Note

Observe Instructions for Use!

Technical data

Permissible load-bearing capacity 1.0 t.

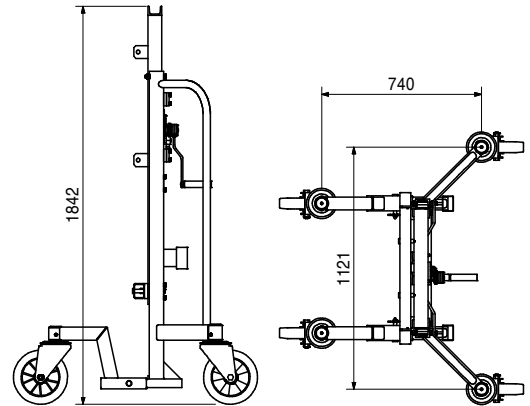
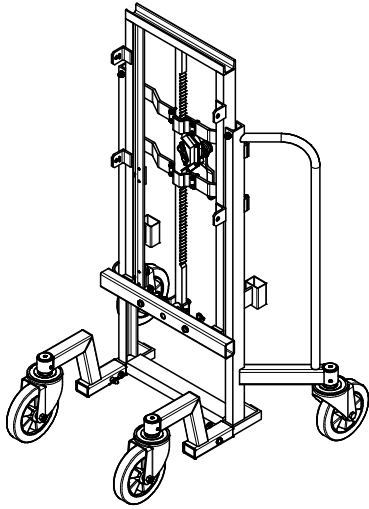

Accessories

118114	14.200
130501	27.100
118605	21.500
117954	21.200
118115	11.000

Support MP - Trolley

Support PERI UP - Trolley

Support Rosette - Trolley

Support Rosette Plus - Trolley

Support PD 8 - Trolley

118114	14.200
--------	--------

Support MP - Trolley

For moving MULTIPROP towers using the Trolley and Winch Unit

Note

Consisting of left and right support (2 parts).

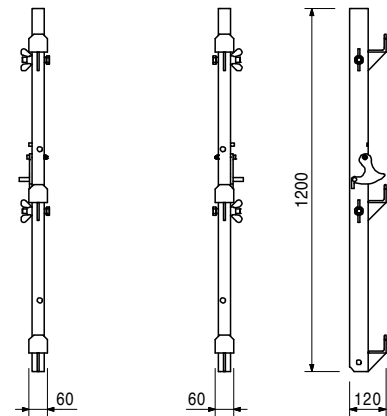
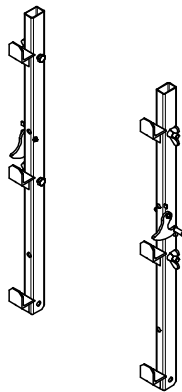

Item. no. Weight kg

Item. no.	Weight kg	Alu Beam MPB 24
079300	24.000	Alu Beam MPB 24, l = 3.00 m
079360	28.800	Alu Beam MPB 24, l = 3.60 m
079420	33.700	Alu Beam MPB 24, l = 4.20 m
079480	38.500	Alu Beam MPB 24, l = 4.80 m
079540	43.300	Alu Beam MPB 24, l = 5.40 m
079600	48.100	Alu Beam MPB 24, l = 6.00 m

Aluminium main beam for the MULTIPROP system.

L
2,998
3,598
4,198
4,798
5,398
5,998

Technical data
 perm. Q = 50 kN
 perm. A = 80 kN
 perm. M = 15 kNm

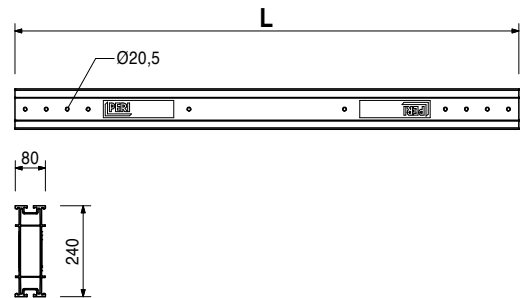
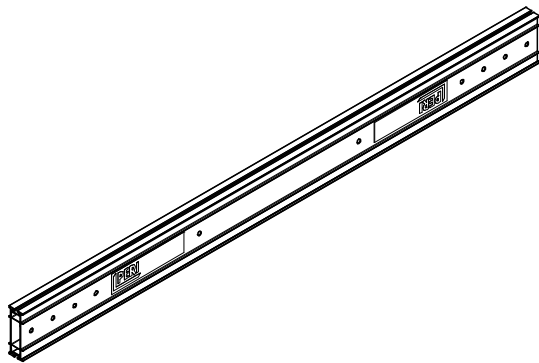

107348	11.000	Splice MPB 24 For connecting the Alu Beams MPB 24.
--------	--------	--

Technical data
 perm. Q = 23.5 kN
 perm. M = 8.8 kNm

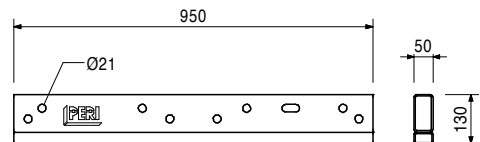
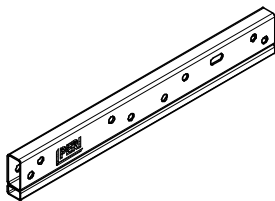

Accessories	
105400	0.330
018060	0.014

Pin Ø 20 x 140, galv.
Cotter pin 4/1, galv.

108339	0.203	Quick Strap MPB 24/GT 24 For assembly of GT 24 girders on the Alu Beam MPB 24.
--------	-------	--

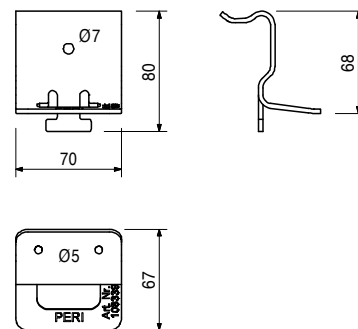
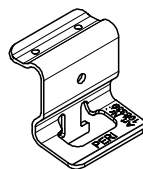

Accessories	
018280	1.000

Double Headed Nail l = 65 mm

Item. no.	Weight kg
111000	0.815

Hook Strap MPB 24/GT 24

For fixing GT 24 girders on the Alu Beam MPB 24.

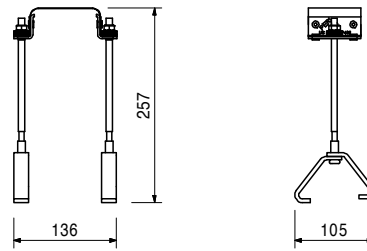
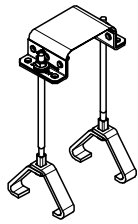

107820	0.057
--------	-------

Strap MPB 24

For fixing Alu Beam MPB 24 to the MULTIPROP prop or mounting the GT 24 girder on the Alu Beam MPB 24.

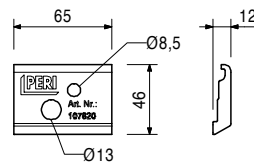

Accessories

111142	0.082
--------	-------

MULTIPROP Bolt with Nut

108213	2.590
--------	-------

Brace Connector MPB 24

For connecting push-pull props or braces to Aluminium Beam MPB 24.

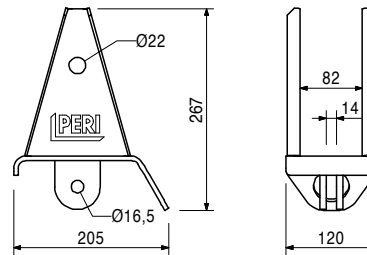
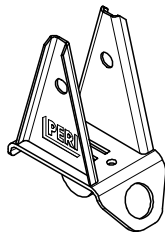

Accessories

104031	0.462
018060	0.014

Fitting pin Ø 21 x 120 Cotter pin 4/1, galv.

Item. no.	Weight kg
104131	3.940

Guardrail Holder SRU/SRZ

For mounting guardrails with Steel Walers SRU and SRZ profile U100 - U140.

Complete with

2 pc. 105400 bolts \varnothing 20 x 140, galv.
2 pc. 018060 cotter pin 4/1, galv.

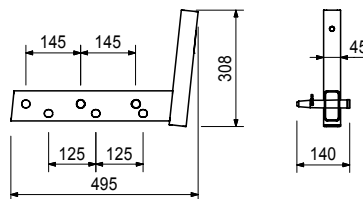
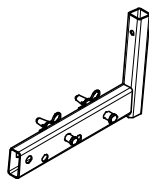

Accessories

116292	4.720
061260	6.150

Guardrail Post HSGP-2

Guardrail Post SGP

116292	4.720
--------	-------

Guardrail Post HSGP-2

As guardrails for various systems.

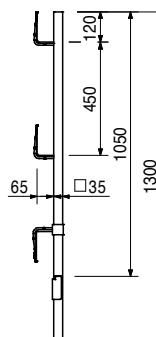

**The optimal System
for every Project and
every Requirement**



Wall Formwork



Column Formwork



Slab Formwork



Climbing Systems



Bridge Formwork



Tunnel Formwork



Shoring Systems



Construction Scaffold



Facade Scaffold



Industrial Scaffold



Access



Protection Scaffold



Safety Systems



System-Independent Accessories



Services



PERI Formwork Systems Inc.
45 Nixon Road
Bolton, ON L7E 1K1
Canada
Tel. +1 (905) 951 - 5400
Fax + 1 (905) 951 - 5454
info@peri.ca
www.peri.ca

