

DOMINO 300

Lightweight panel formwork
for building construction and civil engineering



Edition 07 | 2013

PERI GmbH
Formwork Scaffolding Engineering

Rudolf-Diesel-Strasse 19
89264 Weissenhorn
Germany
Tel. +49 (0)7309.950-0
Fax +49 (0)7309.951-0
info@peri.com
www.peri.com

Important information

All current safety regulations and guidelines must be observed in those countries where our products are used.

The photos shown in this brochure feature construction sites in progress. For this reason, safety and anchor details in particular cannot always be considered as conclusive or final. These are subject to the risk assessment carried out by the contractor.

In addition, computer graphics are used which are to be understood as system representations. For ensuring a better understanding, this and the detailed illustrations shown have been partially reduced to certain aspects. The safety installations which have possibly not been shown in these detailed descriptions must nevertheless be available.

The systems or items shown might not be available in every country.

Safety instructions and load specifications are to be strictly observed at all times. Separate structural calculations are required for any deviations from the standard design data.

The information contained herein is subject to technical changes in the interests of progress. Errors and typographical mistakes reserved.

Content

DOMINO

- 2 The lightweight panel formwork for shuttering of heights up to 3.00 m

Execution details

- 4 Corners, Tjunctions, fillers
- 6 DOMINO accessories
- 8 Components

PERI DOMINO

The lightweight panel formwork for shuttering of heights up to 3.00 m

PERI DOMINO is a lightweight panel formwork system for housing and civil engineering projects with steel framed panels. It was specially developed for shuttering basement walls up to 3.00 m high, foundations and shafts.

Only 4 panel widths

With only 4 panel widths (1.00 m, 0.75 m, 0.50 m and 0.25 m), all ground plans can be formed. The 0.75 m panel is also available as a multi-purpose panel.

DOMINO Alignment Coupler DRS

The Alignment Coupler DRS is used to connect the panel formwork elements. In one single working step, it ensures a flush, aligned and tight connection. The Alignment Coupler DRS allows the use of filler timbers up to 12 cm thick.

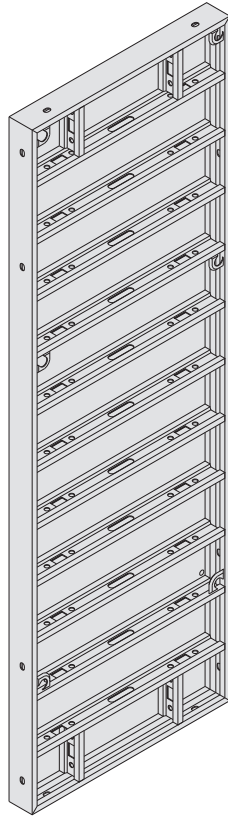

300 x 100

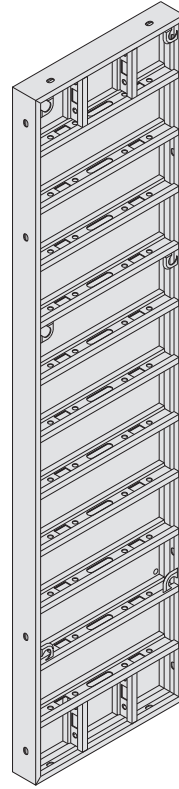

300 x 75

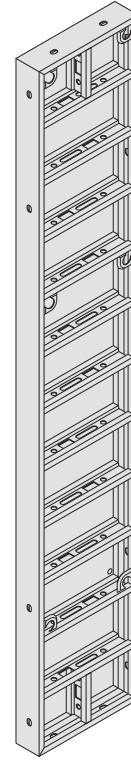

300 x 50

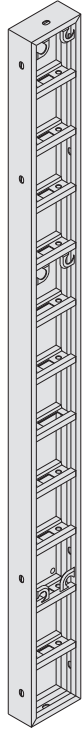

300 x 25

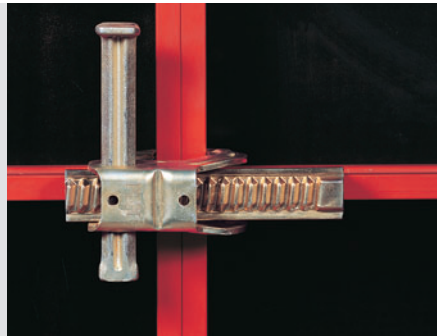
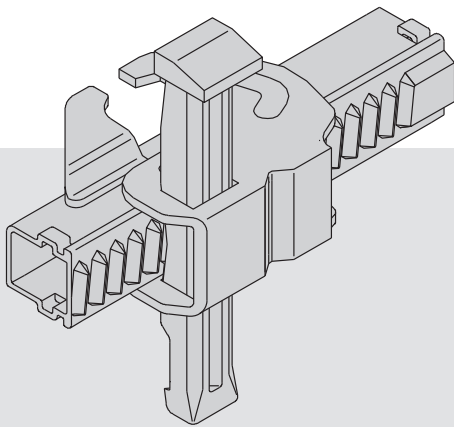

The DOMINO Alignment Coupler DRS on a standard panel joint ...

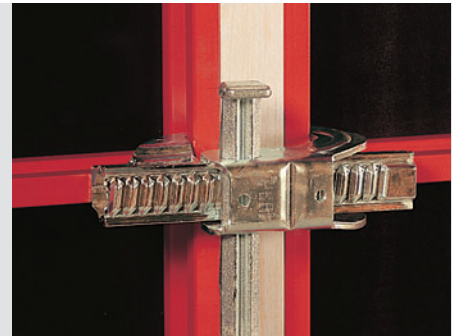

... or with filler timbers up to 12 cm thick.

Fewer ties

DOMINO 300 requires only 2 ties for concreting heights up to 3.0 m. This means 1.5 m² of wall surface per tie.

Permissible fresh concrete pressure

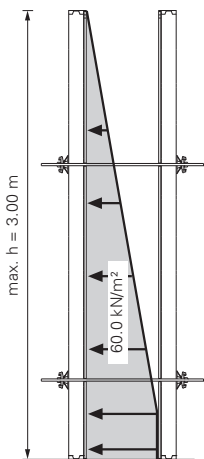

Concreting heights ≤ 3.0 m.
2 ties max. 60 kN/m²,
DIN 18202, Table 3, Line 7.

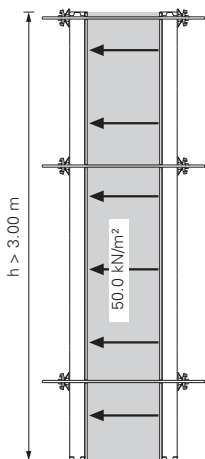

Concreting heights > 3.0 m.
3 ties max. 50 kN/m²,
DIN 18202, Table 3, Line 6.

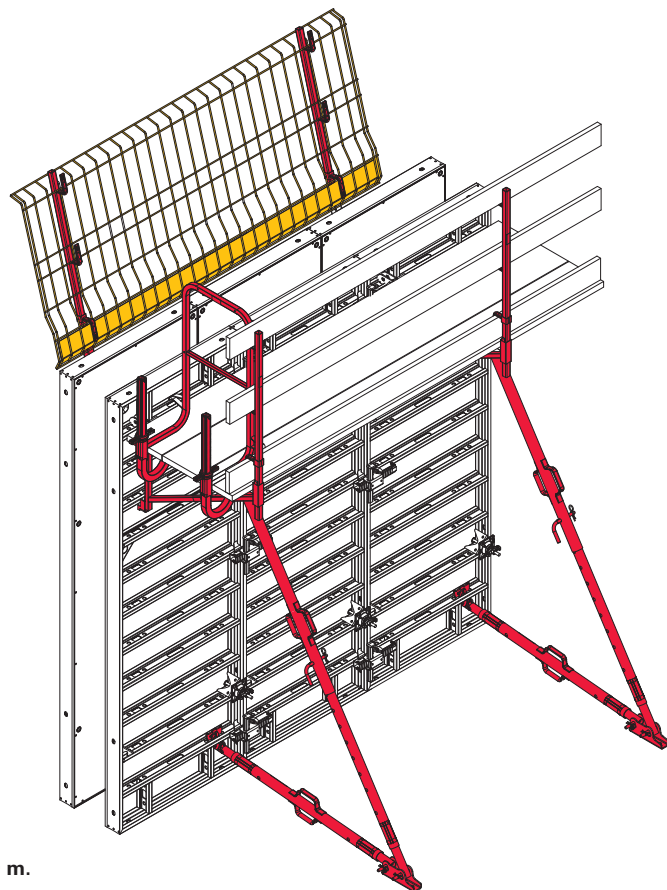

DOMINO Wedge Coupler DKS

The standard component for regular panel joints in the foundations.

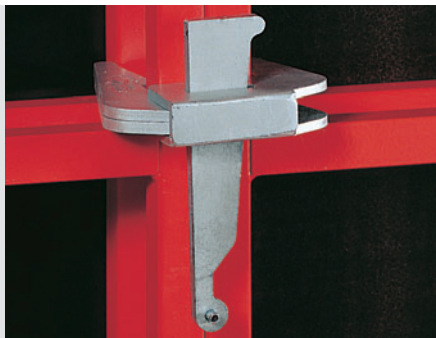

The Wedge Coupler DKS for standard panel joints without high demands.

PERI DOMINO Execution Details

Corners, T-junctions, fillers

Corners

The 50 panel and the External Corner Angle DAW form the external corner. Together with the Wall Thickness Compensator DWD 5, wall thicknesses of 15 cm to 35 cm are possible in 5 cm increments.

Basic rules for corners:

External formwork: Panel D 300 x 50
 Corner Angle DAW
 Internal formwork: Inside Steel Corner DISE, adjusted to suit the wall thickness with Compensator DWD or timber.
 Alternatively: Articulated Corner DGE with 2 x Corner Locking 90°.

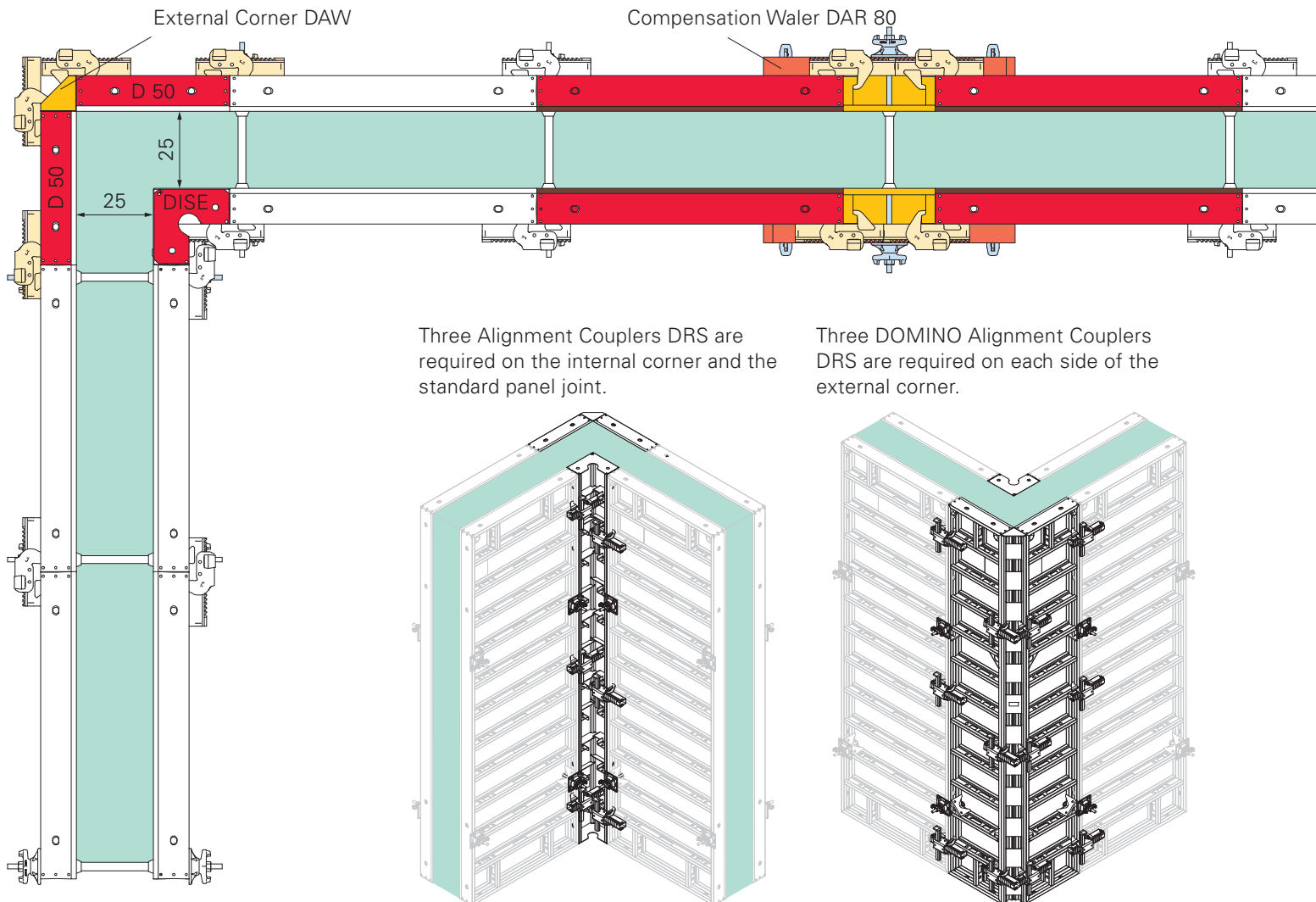
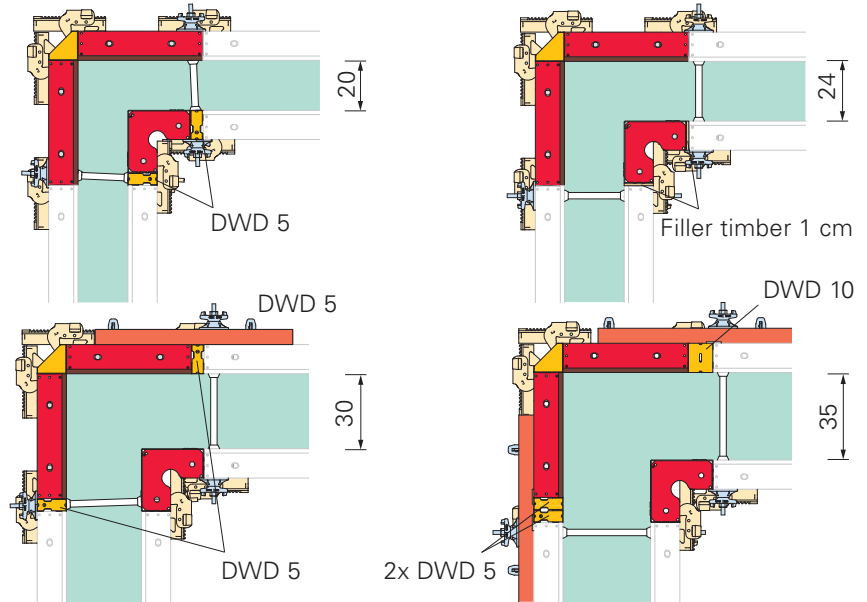

T-Junctions

The 75 panel and Articulated Corner form the T-junction. Together with the Wall Thickness Compensator DWD 5, wall thicknesses from 15 cm to 35 cm in 5 cm increments are possible.

Basic rules for T-junctions:

External formwork: Panel D 300 x 75

Internal formwork: Articulated Corner DGE

DGE

Adjusted to suit the wall thickness with Compensator DWD or timber.

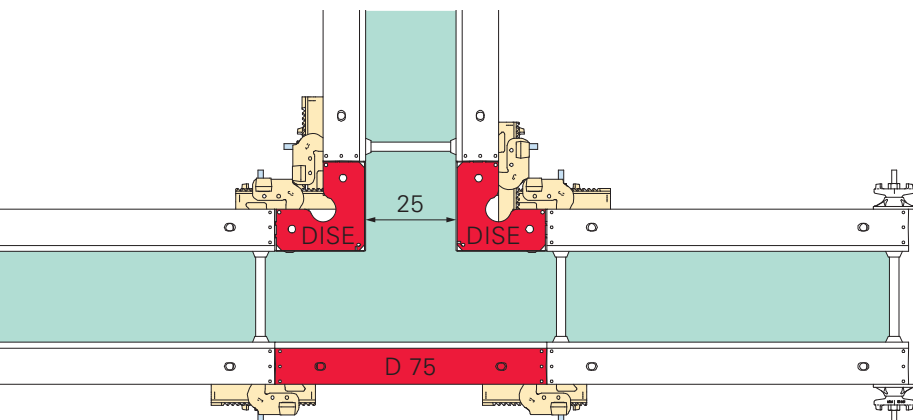
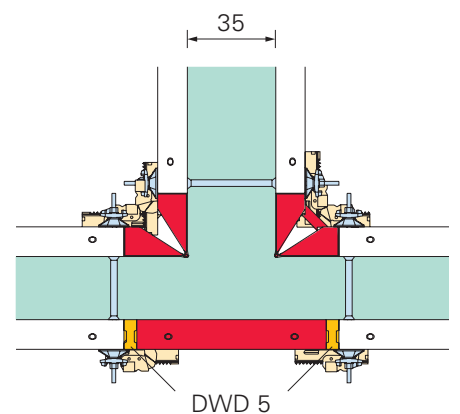
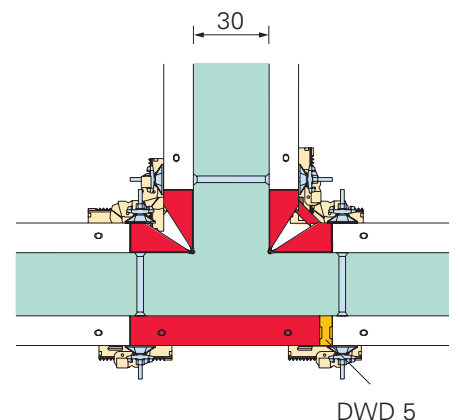
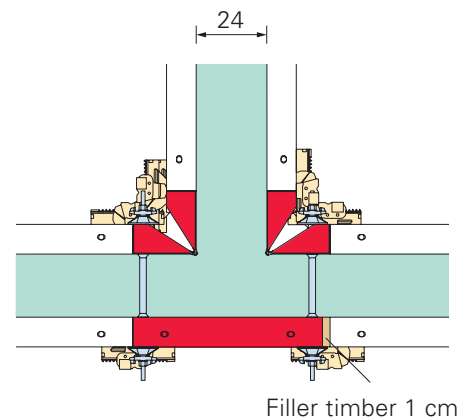
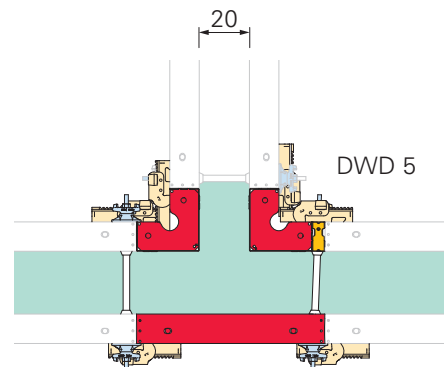

Length compensation

Up to 30 cm with Filler Support and Compensation Waler DAR 80.

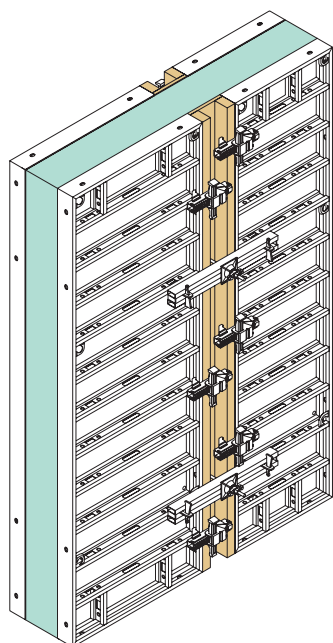

Up to 12 cm with DOMINO Alignment Coupler DRS and filler timber.

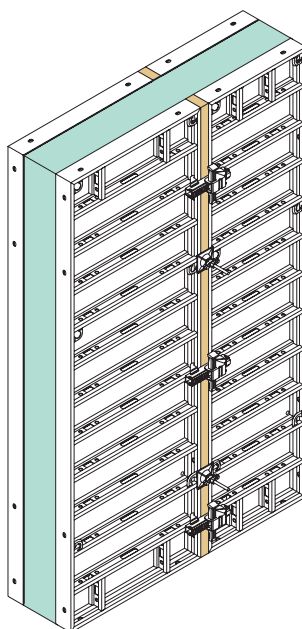

DOMINO Accessories

For quick and easy forming ...

All cross struts of the DOMINO panels have connection holes for accessories. These details allow fast and easy forming operations.

The DOMINO Stacking Device makes transportation by crane and stacking on site much easier. Stacks of panels can also be moved with a fork-lift truck. 8 panels of uniform size can be stacked quickly and safely.

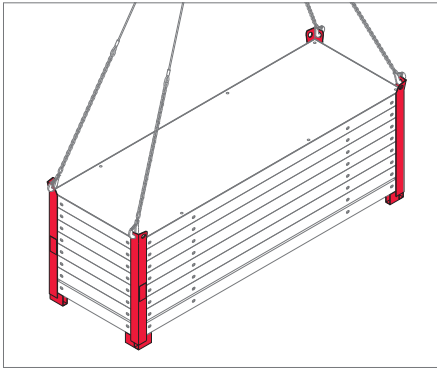

Moving a stack of panels using the DOMINO Stacking Device.

Push-Pull Prop Connector DRA

For connecting push-pull props and kickers to horizontal and vertical struts.

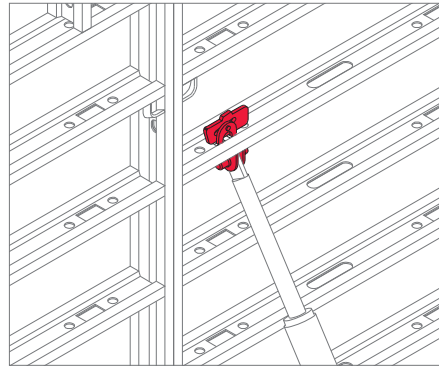

The captive wedge makes assembly operations very easy.

DOMINO Scaffold Bracket DG 85

For an 85 cm wide concreting scaffold. Maximum bracket spacing of 2.00 m with a permissible load of 150 kg/m².

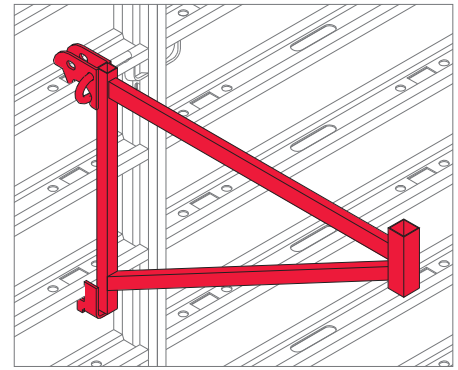

Simply hook on and secure by means of pins.

DOMINO Lifting Hook

For moving vertical DOMINO panels and panel units. 2 Lifting Hooks per transport unit are to be used - load-carrying capacity per hook is 500 kg.

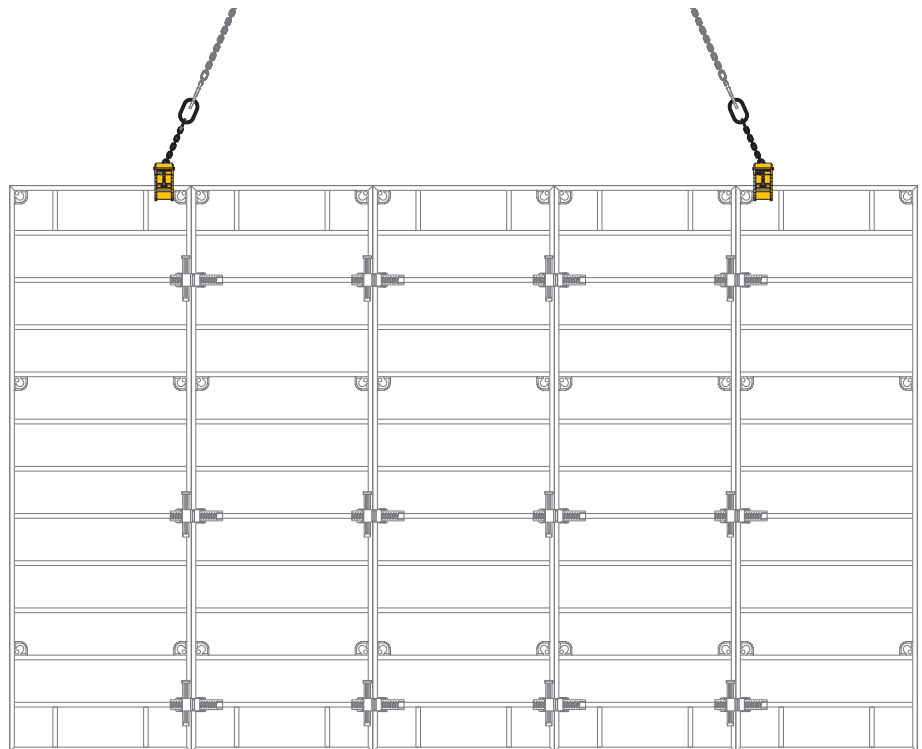
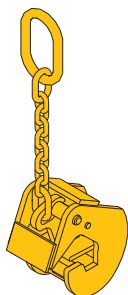

... also for foundations

All DOMINO panels are suitable for the shuttering of foundations.

The special feature is, however, the panels with inset tie points. This allows simple anchoring operations even in the foundations.

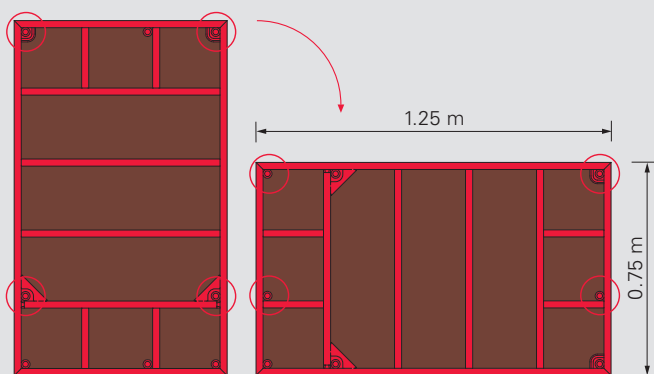

The 1.25 m and 1.50 m high DOMINO panels have inset tie points and can also be used horizontally without any problems.

Individual and strip foundations are realized using the Foundation Tie Clamp and Top Tie Bracket.

The DOMINO Foundation Tie Clamp for easy shuttering of foundations, replacing the bottom tie position as well as saving work space and thus earthmoving operations.

Ties are tensioned accurately by means of a self-cleaning hexagonal spindle.

Using the Top Tie Bracket for the top anchoring points means the DOMINO panels do not have to be aligned exactly. It is possible to anchor at any position on the panel.

Foundation Tie Clamp



Top Tie Bracket



Perforated Foundation Tie

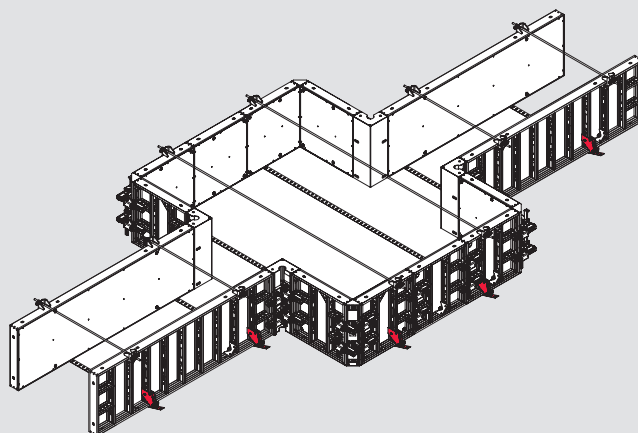
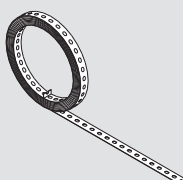

Regardless whether forming individual or strip foundations, DOMINO panels and accessories realize this in a very easy and straightforward way.

DOMINO 300 Panel Formwork

Item no. Weight kg

066000 102,000

Panel D 300 x 100

Steel panel with 15 mm plywood.

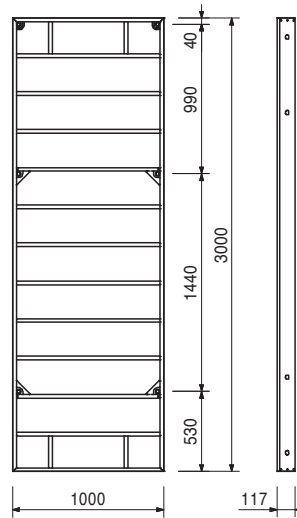
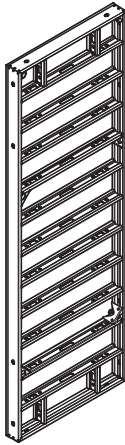

066002 83,100

Panel D 300 x 75

Steel panel with 15 mm plywood.

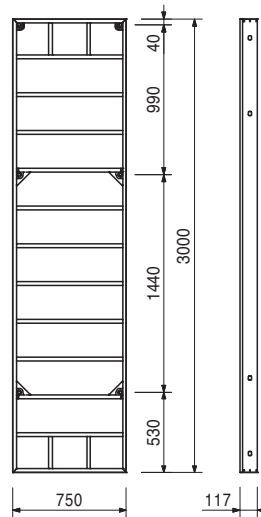
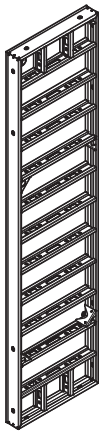

066005 63,300

Panel D 300 x 50

Steel panel with 15 mm plywood.

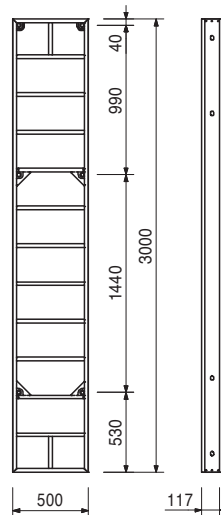

DOMINO 300 Panel Formwork



| Item no. | Weight kg |
|----------|-----------|
| 066006 | 43,700 |

Panel D 300 x 25
Steel panel with 15 mm plywood.

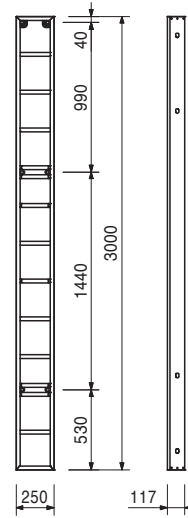

| | |
|--------|--------|
| 066004 | 90,600 |
|--------|--------|

Multi Panel DM 300 x 75
Steel panel with 15 mm plywood. For oblique angles, wall connections etc.

Complete with
69 pc. 030290 Plug Ø 20 mm

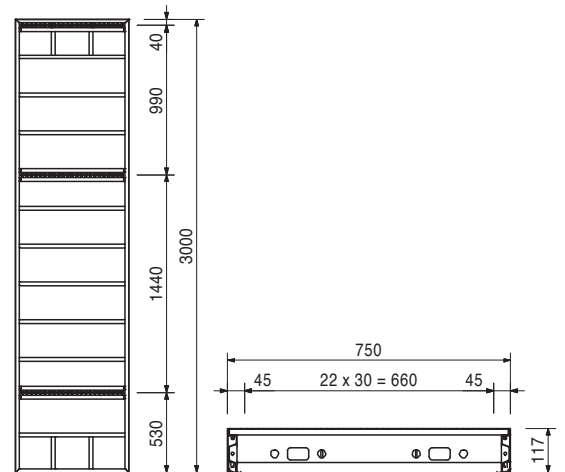
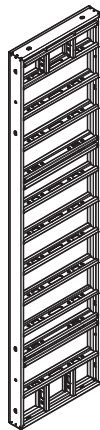

| | |
|--------|--------|
| 126298 | 80,400 |
|--------|--------|

Inside Steel Corner DISE 300

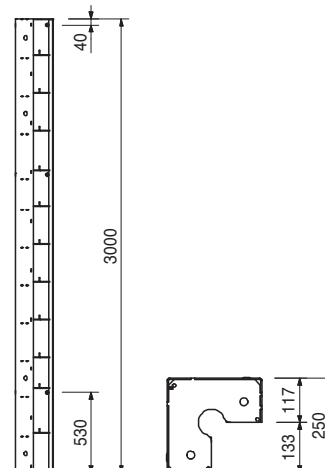

DOMINO 300 Panel Formwork



| Item no. | Weight kg |
|----------|-----------|
| 066009 | 47,800 |

Articulated Corner DGE 300

Alu panel with aluminium formlining. For oblique angles from 75°, can be used internally and externally.

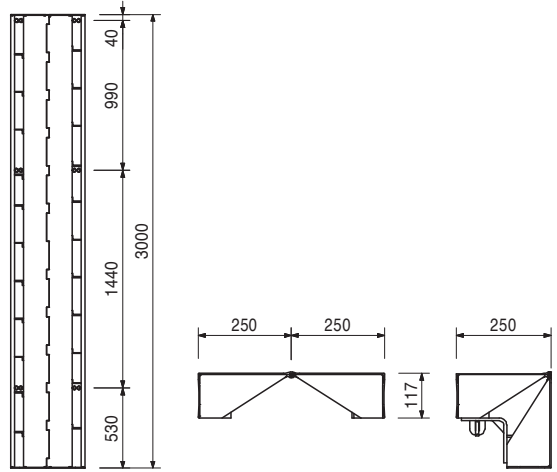

| | |
|--------|-------|
| 066010 | 9,360 |
|--------|-------|

Wall Thickness Compensation DWD 300 x 5

For adjusting to wall thicknesses in corners: with DOMINO.

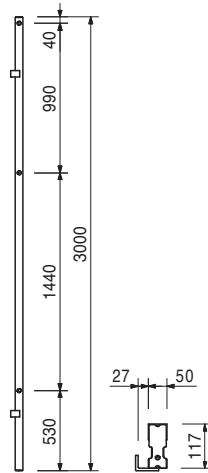

| | |
|--------|--------|
| 066008 | 12,500 |
|--------|--------|

External Corner DAW 300

For panel connections at 90° external corners.

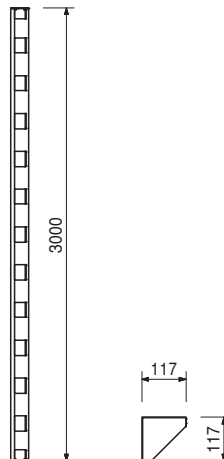

DOMINO 300 Panel Formwork

| Item no. | Weight kg |
|----------|-----------|
| 066011 | 5,000 |
| 066012 | 4,700 |

Filler Supports DPA 300
Filler Support DPA 300
Filler Support DPA 300/27

For compensation with 21 or rather 27 mm filler plates.

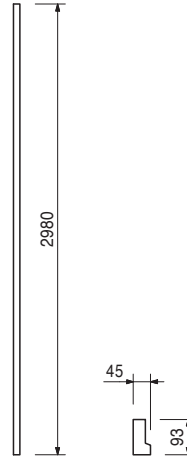

| | |
|--------|---------|
| 111617 | 167,000 |
|--------|---------|

Shaft Panel DSE 300

Element for moving complete internal shaft formwork.

Technical Data

Permissible load-bearing point capacity 2.0 t.

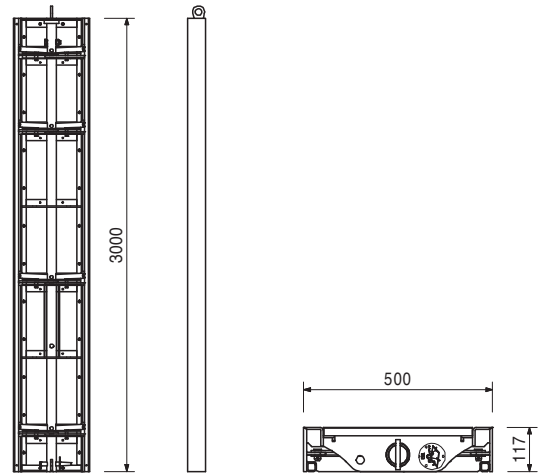

Accessories

| | |
|--------|-------|
| 111665 | 4,360 |
|--------|-------|

Spindle Shaft Element DSE

DOMINO 300 Panel Formwork



| Item no. | Weight kg |
|----------|-----------|
| 066087 | 2,550 |

Chamfer Strip DSD 300

For DOMINO Column Formwork and external corners.

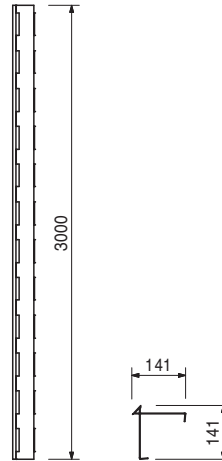

| | |
|--------|--------|
| 066013 | 55,400 |
| 066014 | 52,000 |
| 066015 | 48,300 |
| 066016 | 39,000 |

Column Panels DS 300

Column Panel DS 300 x 40
Column Panel DS 300 x 35
Column Panel DS 300 x 30
Column Panel DS 300 x 20

B

400
 350
 300
 200

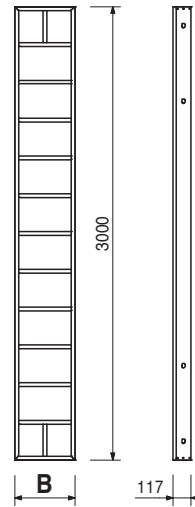

DOMINO 300 Panel Formwork



| Item no. | Weight kg |
|----------|-----------|
| 101927 | 16,200 |
| 108855 | 17,900 |

Stopend Panels DOMINO AT 250
Stopend Panel DOMINO AT 250 x 3
Stopend Panel DOMINO AT 250 x 5
 External unit for stopend formwork.

Note
 Concrete cover approx. 30 or 50 mm.

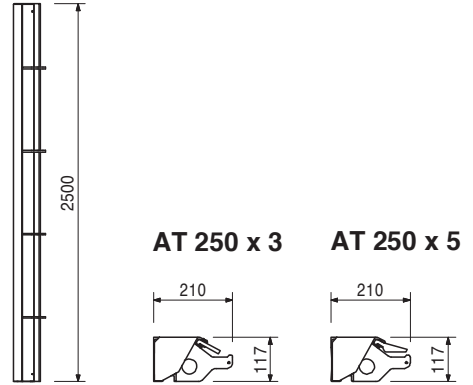

| | |
|--------|--------|
| 101928 | 27,100 |
| 101929 | 31,200 |
| 101930 | 36,000 |
| 101931 | 39,700 |

Stopend Panels DOMINO MTF 250
Stopend Panel DOMINO MTF 250 x 20
Stopend Panel DOMINO MTF 250 x 24/25
Stopend Panel DOMINO MTF 250 x 30
Stopend Panel DOMINO MTF 250 x 35/36
 Center section with waterstop bar installation for stopend formwork.

| B |
|-----|
| 118 |
| 158 |
| 218 |
| 268 |

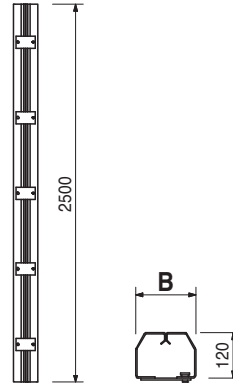

| | |
|--------|--------|
| 124498 | 56,500 |
|--------|--------|

Panel D 150 x 100
 Steel panel with 15 mm plywood.

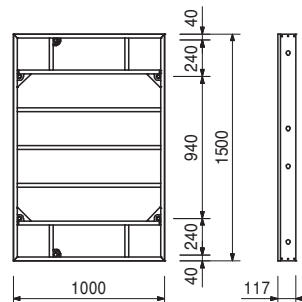
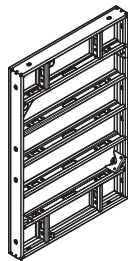

DOMINO 300 Panel Formwork

Item no. Weight kg

124504 46,100

Panel D 150 x 75

Steel panel with 15 mm plywood.

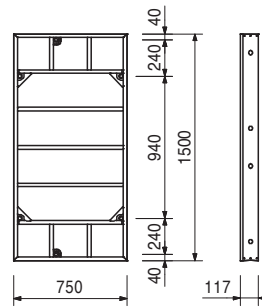

124510 34,200

Panel D 150 x 50

Steel panel with 15 mm plywood.

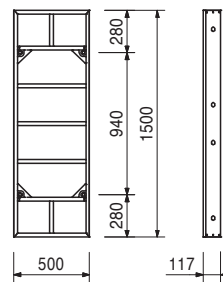

124517 26,800

Panel D 150 x 35

Steel panel with 15 mm plywood.

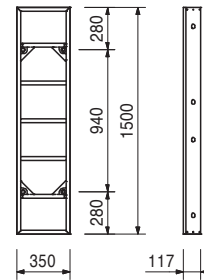

124523 22,700

Panel D 150 x 25

Steel panel with 15 mm plywood.

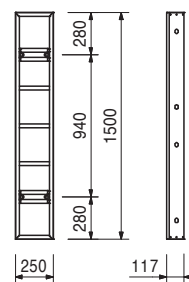

DOMINO 300 Panel Formwork



| Item no. | Weight kg |
|----------|-----------|
| 124538 | 51,300 |

Multi Panel DM 150 x 75

Steel panel with 15 mm plywood. For oblique angles, wall connections etc.

Complete with

46 pc. 030290 Plug Ø 20 mm

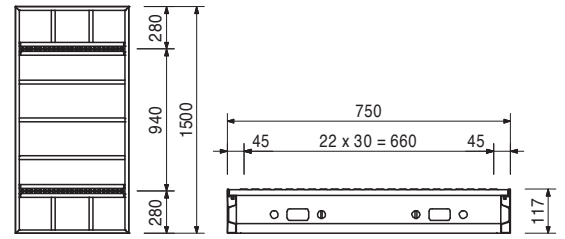
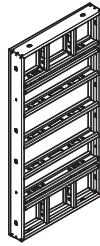

| | |
|--------|--------|
| 126286 | 40,800 |
|--------|--------|

Inside Steel Corner DISE 150

For 90° internal corners.

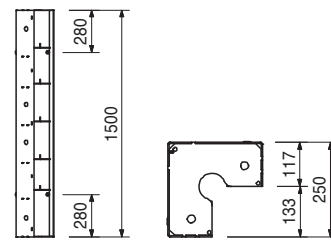

| | |
|--------|--------|
| 124605 | 23,700 |
|--------|--------|

Articulated Corner DGE 150

Alu panel with aluminium formlining. For oblique angles from 75°, can be used internally and externally.

Complete with

1 pc. 066100 Positioning DEA 90°

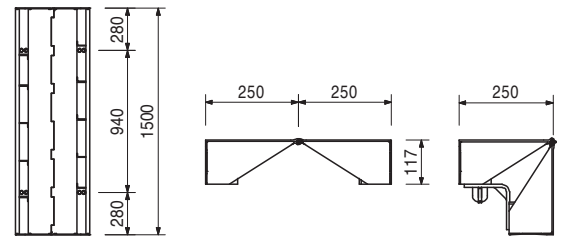

| | |
|--------|-------|
| 124608 | 6,490 |
|--------|-------|

Outside Corner Angle DAW 150

For panel connections at 90° external corners.

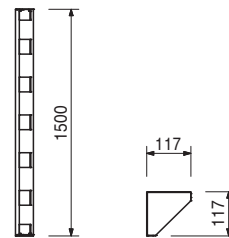

DOMINO 300 Panel Formwork



| Item no. | Weight kg |
|----------|-----------|
| 125944 | 4,790 |
| 125660 | 7,060 |

Wall Thickness Compensation DWD 150
Wall Thickness Comp. DWD 150/5
Wall Thickness Comp. DWD 150/10
 For adjusting to wall thicknesses.

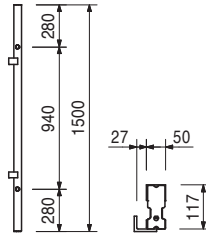

| | |
|--------|-------|
| 124577 | 2,480 |
|--------|-------|

Filler Support DPA 150
 For compensation with 21 mm filler plates.

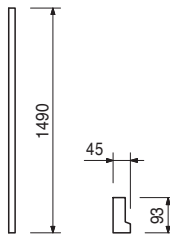

| | |
|--------|--------|
| 066040 | 47,300 |
|--------|--------|

Panel D 125 x 100
 Steel panel with 15 mm plywood.

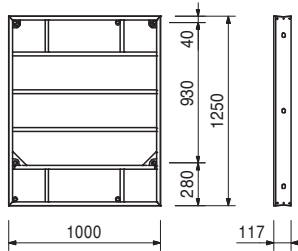
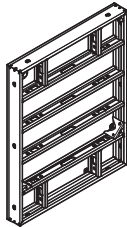

| | |
|--------|--------|
| 066041 | 38,700 |
|--------|--------|

Panel D 125 x 75
 Steel panel with 15 mm plywood.

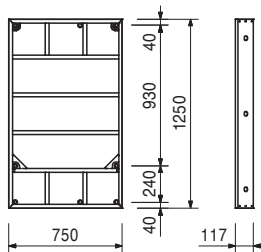
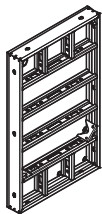

DOMINO 300 Panel Formwork

| Item no. | Weight kg |
|----------|-----------|
| 066043 | 28,600 |

Panel D 125 x 50
Steel panel with 15 mm plywood.

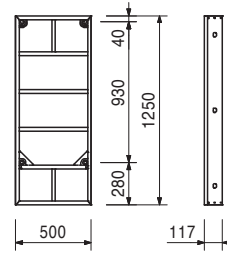

| | |
|--------|--------|
| 125494 | 22,400 |
|--------|--------|

Panel D 125 x 35
Steel panel with 15 mm plywood.

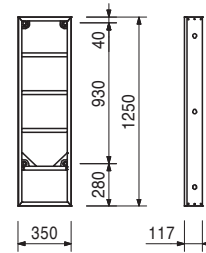

| | |
|--------|--------|
| 066044 | 18,600 |
|--------|--------|

Panel D 125 x 25
Steel panel with 15 mm plywood.

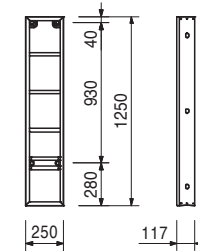

| | |
|--------|--------|
| 066050 | 31,000 |
|--------|--------|

Panel DA 125 x 100
Alu panel with 15 mm plywood.

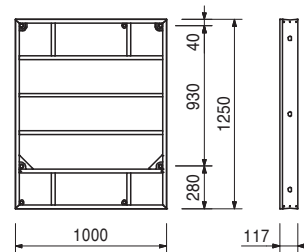
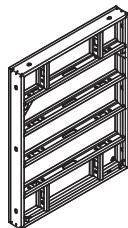

DOMINO 300 Panel Formwork



| Item no. | Weight kg |
|----------|-----------|
| 066051 | 24,800 |

Panel DA 125 x 75
Alu panel with 15 mm plywood.

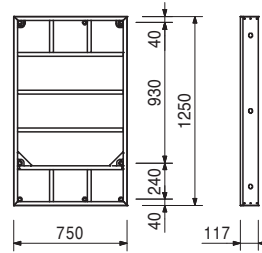
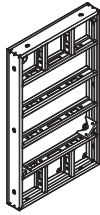

| | |
|--------|--------|
| 066042 | 43,700 |
| 066052 | 27,300 |

Multi Panels DM/DMA 125
Multi Panel DM 125 x 75
Multi Panel DMA 125 x 75
Steel/alu panel with 15 mm plywood. For oblique angles, wall connections etc.

Complete with
46 pc. 030290 Plug Ø 20 mm

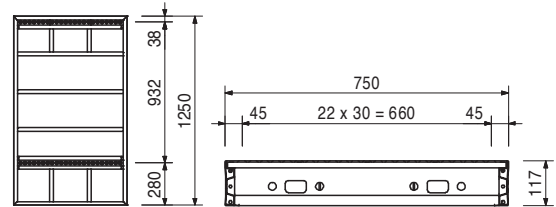
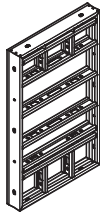

| | |
|--------|--------|
| 126280 | 34,200 |
|--------|--------|

Inside Steel Corner DISE 125
For 90° internal corners.

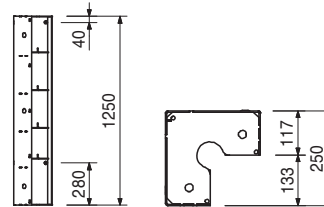

| | |
|--------|--------|
| 066047 | 21,300 |
|--------|--------|

Articulated Corner DGE 125
Alu panel with aluminium formlining. For oblique angles from 75°, can be used internally and externally.

Complete with
1 pc. 066100 Positioning DEA 90°

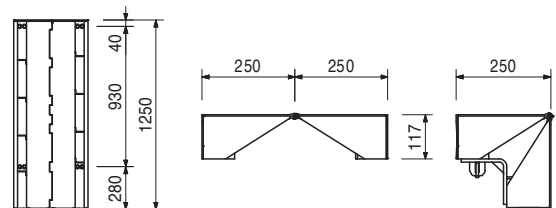

| Item no. | Weight kg |
|----------|-----------|
|----------|-----------|

| | | |
|--------|-------|--|
| 066048 | 4,030 | Wall Thickness Compensation DWD 125 |
| 101964 | 5,940 | Wall Thickness Comp. DWD 125 x 5 |
| | | Wall Thickness Comp. DWD 125 x 10 |

For adjusting to wall thicknesses.

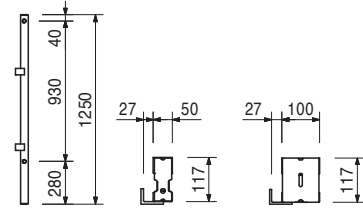

| | | |
|--------|-------|-------------------------------------|
| 066046 | 5,490 | Outside Corner Angle DAW 125 |
|--------|-------|-------------------------------------|

For panel connections at 90° external corners.

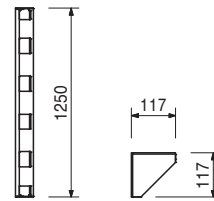

| | | |
|--------|-------|-------------------------------|
| 066053 | 2,070 | Filler Support DPA 125 |
|--------|-------|-------------------------------|

For compensation with 21mm filler plates.

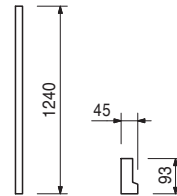

| | | |
|--------|--------|----------------------------|
| 111655 | 77,100 | Shaft Panel DSE 125 |
|--------|--------|----------------------------|

Element for moving complete internal shaft formwork.

Technical Data
Permissible load-bearing point capacity 2.0 t.

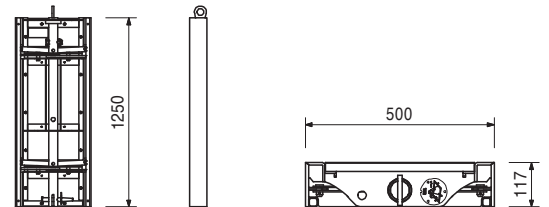

| | | |
|--------|-------|----------------------------------|
| 111665 | 4,360 | Spindle Shaft Element DSE |
|--------|-------|----------------------------------|

Accessories

DOMINO 300 Panel Formwork



| Item no. | Weight kg |
|----------|-----------|
| 101934 | 8,140 |
| 108856 | 8,980 |

Stopend Panles DOMINO AT 125
Stopend Panel DOMINO AT 125 x 3
Stopend Panel DOMINO AT 125 x 5
 External piece for stopend formwork.

Note
 Concrete cover approx. 30 or 50 mm.

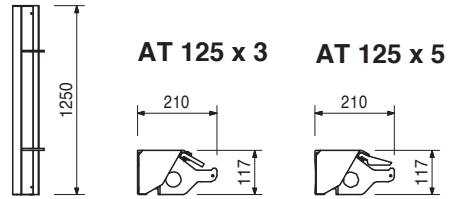

| | |
|--------|--------|
| 101935 | 14,600 |
| 101936 | 15,200 |
| 101937 | 17,500 |
| 101940 | 19,300 |

Stopend Panels DOMINO MTF 125
Stopend Panel DOMINO MTF 125 x 20
Stopend Panel DOMINO MTF 125 x 24/25
Stopend Panel DOMINO MTF 125 x 30
Stopend Panel DOMINO MTF 125 x 35/36

B

118
 158
 218
 268

With waterstop bar installation support for stopend formwork.

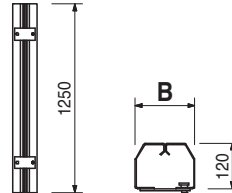

| | |
|--------|--------|
| 066064 | 12,100 |
|--------|--------|

Panel D 75 x 25
 Steel panel with 15 mm plywood.

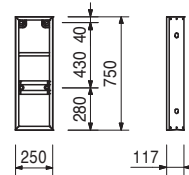

| | |
|--------|--------|
| 125486 | 14,500 |
|--------|--------|

Panel D 75 x 35
 Steel panel with 15 mm plywood.

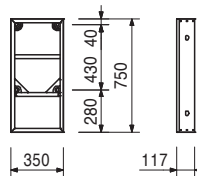

| | |
|--------|--------|
| 066063 | 19,300 |
|--------|--------|

Panel D 75 x 50
 Steel panel with 15 mm plywood.

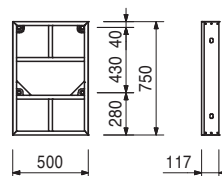

DOMINO 300 Panel Formwork



| Item no. | Weight kg |
|----------|-----------|
| 066061 | 26,500 |

Panel D 75 x 75
Steel panel with 15 mm plywood.

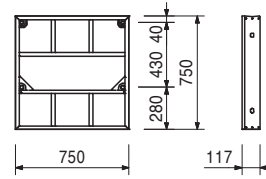
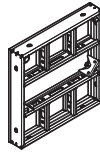

| | |
|--------|--------|
| 066060 | 32,400 |
|--------|--------|

Panel D 75 x 100
Steel panel with 15 mm plywood.

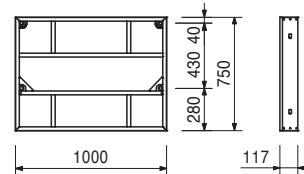
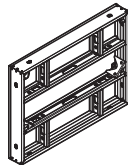

| | |
|--------|--------|
| 066062 | 31,600 |
|--------|--------|

Multi Panel DM 75 x 75
Steel panel with 15 mm plywood. For oblique angles, wall connections, stopends etc.

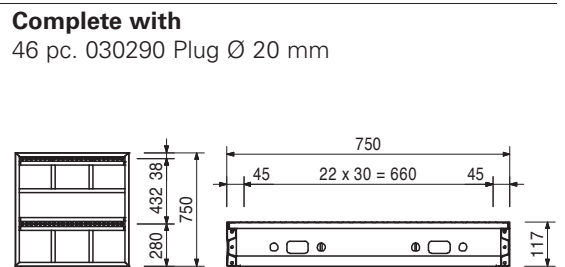
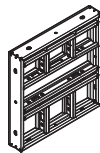

Complete with
46 pc. 030290 Plug Ø 20 mm

| | |
|--------|--------|
| 126274 | 21,000 |
|--------|--------|

Inside Steel Corner DISE 75
For 90° internal corners.

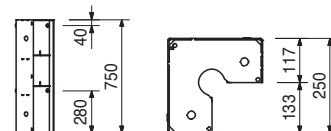

| | |
|--------|--------|
| 066067 | 14,200 |
|--------|--------|

Articulated Corner DGE 75
Alu panel with aluminium formlining. For oblique angles from 75°, can be used internally and externally.

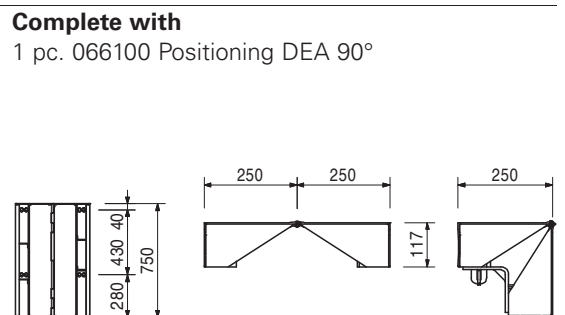

Complete with
1 pc. 066100 Positioning DEA 90°

DOMINO 300 Panel Formwork



| Item no. | Weight kg |
|----------|-----------|
| 066068 | 2,520 |

Wall Thickness Compensation DWD 75 x 5
For adjusting to wall thicknesses.

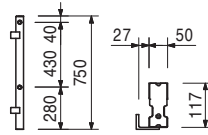

| | |
|--------|-------|
| 066066 | 3,500 |
|--------|-------|

Outside Corner Angle DAW 75
For panel connections at 90° external corners.

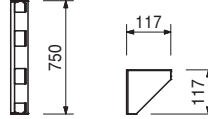

| | |
|--------|-------|
| 066080 | 3,940 |
|--------|-------|

Alignment Coupler DRS
For all panel connections for DOMINO. Fillers up to 12 cm.

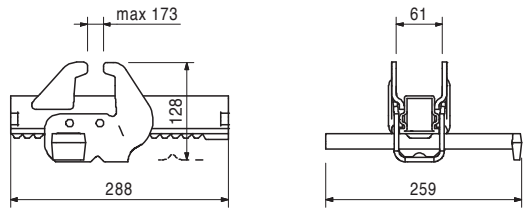
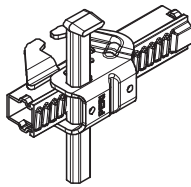

| | |
|--------|-------|
| 066081 | 1,160 |
|--------|-------|

Wedge Clamp DKS
For panel connections without high loads with DOMINO.

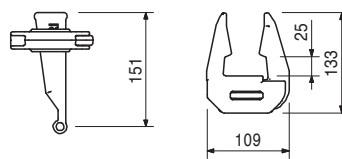
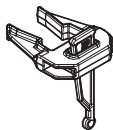

| | |
|--------|-------|
| 066084 | 8,510 |
|--------|-------|

Compensation Waler DAR 80
For longitudinal compensation, height extensions, stopend formwork and special applications with DOMINO. With captive connecting components.

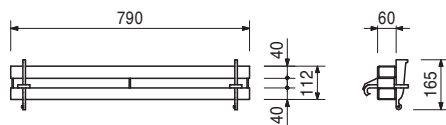
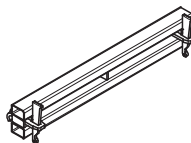

| Item no. | Weight kg |
|----------|-----------|
| 110406 | 2,100 |

Stopend Tie-2 DSA

For force application from the stopend formwork into DOMINO panels. DW 15 thread.

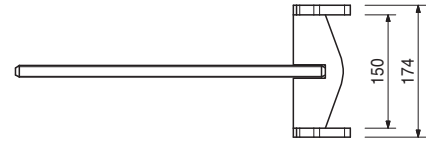
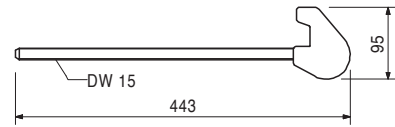
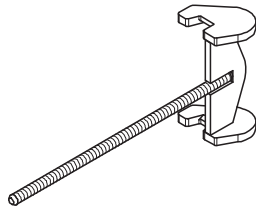

| | |
|--------|-------|
| 030290 | 0,002 |
|--------|-------|

Plug Ø 20 mm

For closing Ø 20 mm tie holes which are not required.

Note

Delivery unit 500 pieces.

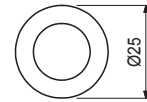
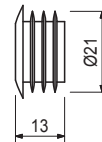

| | |
|--------|-------|
| 066088 | 2,030 |
|--------|-------|

DOMINO Chamfer Strip DSD 250

For DOMINO Column Formwork and outside corners.

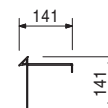

| | |
|--------|-------|
| 066086 | 1,110 |
|--------|-------|

Top Tie Bracket DAH

For grid-independent anchoring outside of the panel, especially for foundations.

Technical Data

Permissible anchor tensile force:

Hole 1 = 20 kN

Hole 2 = 10 kN

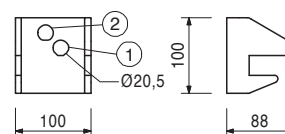
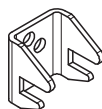

| Item no. | Weight kg |
|----------|-----------|
| 066100 | 1,470 |

Positioning DEA 90°
For 90° internal corners.

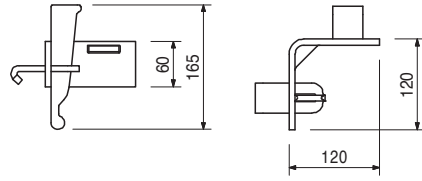
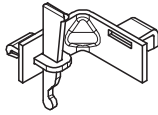

| | |
|--------|-------|
| 066095 | 1,060 |
|--------|-------|

Positioning DGE 135° internal
For 135° internal corners.

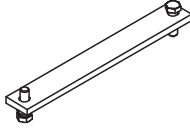

Complete with
2 pc. 710224 Bolt ISO 4017 M12 x 40-8.8, galv.

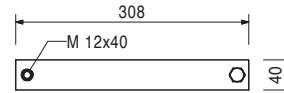

| | |
|--------|-------|
| 066097 | 1,560 |
|--------|-------|

Positioning DGE 135° external
For 135° external corners.

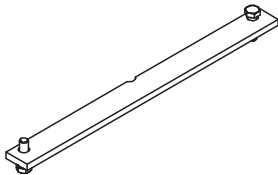

Complete with
2 pc. 710224 Bolt ISO 4017 M12 x 40-8.8, galv.

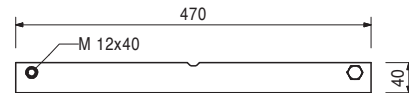

| | |
|--------|-------|
| 111665 | 4,360 |
|--------|-------|

Spindle Shaft Element DSE
For use with internal Shaft Panel DSE. For spindling back to the starting position. 1 piece per Shaft Panel DSE.

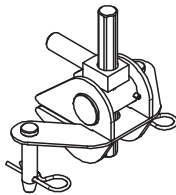

Complete with
2 pc. 105822 Bolt Ø 20 x 102, galv.
2 pc. 022230 Cotter Pin 5/1, galv.

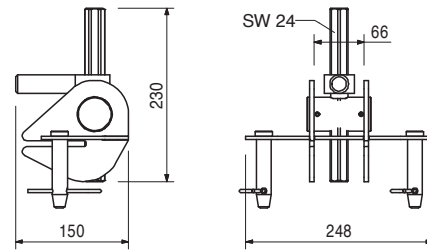

| | |
|--------|-------|
| 066085 | 6,970 |
|--------|-------|

Scaffold Bracket DG 85
For assembly of a working and concreting scaffold with DOMINO.

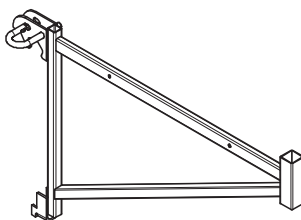

Technical Data
Permissible load 150 kg/m² with maximum width of influence 2.00 m.

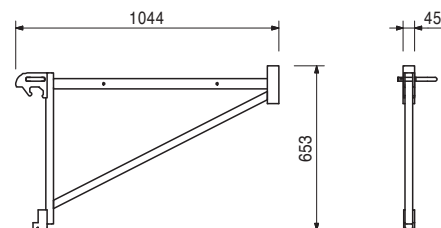

Accessories

| | |
|--------|-------|
| 116292 | 4,730 |
|--------|-------|

Guardrail Post HSGP-2

DOMINO 300 Panel Formwork



| Item no. | Weight kg |
|----------|-----------|
| 106877 | 2,730 |

Guardrail Post Holder DOMINO
For assembling a guardrail to DOMINO panels.

Complete with
1 pc. 018060 Cotter Pin 4/1, galv.

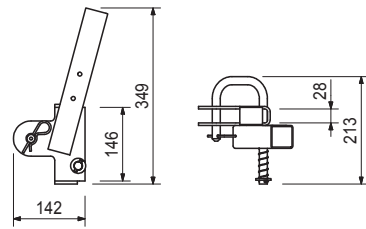

Accessories
Guardrail Post HSGP-2

| | |
|--------|-------|
| 116292 | 4,730 |
|--------|-------|

116292 4,730 **Guardrail Post HSGP-2**
As guardrail for different systems.

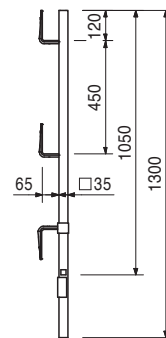

| | |
|--------|-------|
| 066091 | 6,330 |
|--------|-------|

Lifting Hook DOMINO 500 kg
For transporting DOMINO panels.

Note
Follow Instructions for Use!
Technical Data
Permissible load-bearing capacity 500 kg.

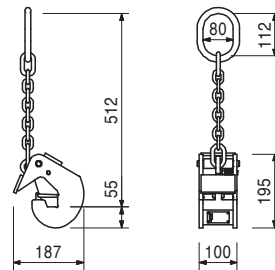

| Item no. | Weight kg |
|----------|-----------|
| 066094 | 8,040 |

Stacking Device DOMINO DSR, galv.

For stacking and transportation of 2-8 DOMINO panels of all sizes. Suitable for crane and fork-lift transport. 4 pieces per stack.

Note

Follow Instructions for Use!

Technical Data

Permissible load-bearing capacity 250 kg per piece, 1 t per stack.

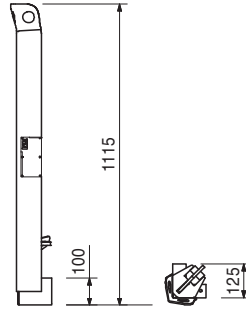

| | |
|--------|-------|
| 066093 | 0,020 |
|--------|-------|

Stacking Aid DOMINO DSH

Plastic. Prevents the panel from sliding sideways.

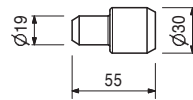

| | |
|--------|-------|
| 066099 | 0,030 |
|--------|-------|

Stacking Aid DOMINO DSW

For stacking DOMINO panels. 4 panels per stack.

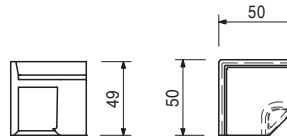
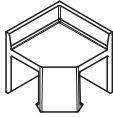

DOMINO 300 Panel Formwork



| Item no. | Weight kg |
|----------|-----------|
| 027680 | 49,600 |

Connector SB-1,2 - MX/TR/D

For assembly of Brace Frame SB-1.2 to MAXIMO, TRIO and DOMINO panels.

Technical Data

Permissible load-bearing point capacity 1.0 t with crane sling angle $\leq 15^\circ$.

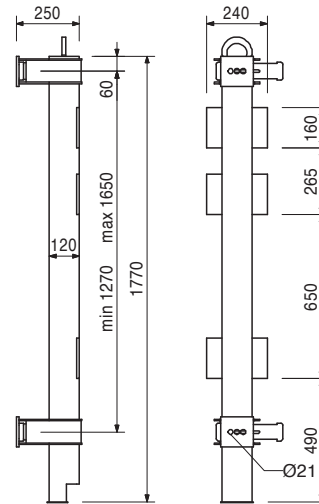

Accessories

| | | |
|--------|-------|--------------------------------------|
| 027690 | 0,368 | Bolt SB-TRIO/DOMINO, galv. |
| 027590 | 2,400 | Hook Strap for SB-1, 2, galv. |
| 113255 | 0,414 | Bolt SB-MAXIMO, galv. |
| 114107 | 1,190 | Sleeve SB-MAXIMO, galv. |
| 114417 | 1,400 | Sleeve SB-MAXIMO WDMX |

| | |
|--------|-------|
| 025740 | 9,140 |
|--------|-------|

Connector SB-A, B, C - MX/TR/D

For connecting MAXIMO, TRIO and DOMINO panels with Brace Frames SB-A0, A, B, C.

Note

1 piece per anchor point.

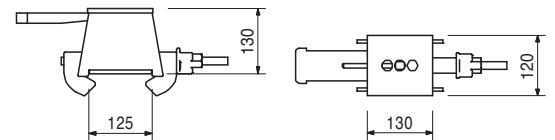
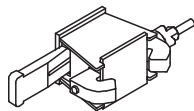

Accessories

| | | |
|--------|-------|-----------------------------------|
| 027690 | 0,368 | Bolt SB-TRIO/DOMINO, galv. |
| 113255 | 0,414 | Bolt SB-MAXIMO, galv. |
| 114107 | 1,190 | Sleeve SB-MAXIMO, galv. |
| 114417 | 1,400 | Sleeve SB-MAXIMO WDMX |

| | |
|--------|-------|
| 027690 | 0,368 |
|--------|-------|

Bolt SB-TRIO/DOMINO, galv.

For panel formwork with 12 cm overall thickness.

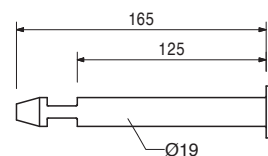
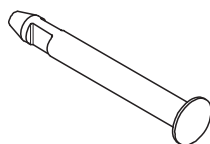

Accessories

| | | |
|--------|-------|--------------------------------|
| 114107 | 1,190 | Sleeve SB-MAXIMO, galv. |
| 114417 | 1,400 | Sleeve SB-MAXIMO WDMX |

| Item no. | Weight kg |
|----------|-----------|
| 066090 | 2,480 |

Foundation Tie Clamp DOMINO DLS

For anchoring foundation formwork in combination with the Perforated Foundation Tie.

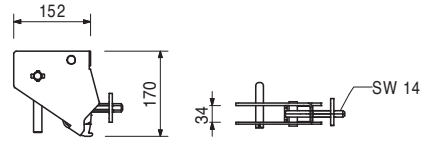
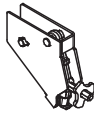

| | |
|--------|-------|
| 023020 | 0,676 |
|--------|-------|

Perforated Foundation Tie, 25 m

For use with Foundation Tie Clamp TRIO, DOMINO and HANDSET.

Technical Data

Permissible tension force 12.9 kN.

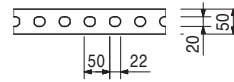

| | |
|--------|-------|
| 066082 | 1,040 |
|--------|-------|

Brace Connector DRA

For connecting push pull props and kicker braces at DOMINO elements.

Complete with

- 1 pc. 027170 Pin \varnothing 16 x 42, galv.
- 1 pc. 018060 Cotter Pin 4/1, galv.

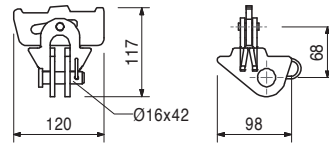
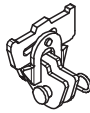

| | |
|--------|--------|
| 117466 | 10,600 |
|--------|--------|

Push-Pull Prop RS 210, galv.

Extension length $L = 1.30 - 2.10$ m.
For aligning PERI formwork systems and precast concrete elements.

Note

Permissible load see PERI Design Tables.

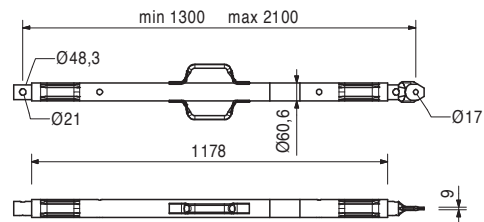
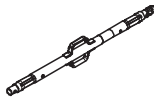

| | |
|--------|--------|
| 118238 | 12,200 |
|--------|--------|

Push-Pull Prop RS 260, galv.

Extension length $L = 2.30 - 2.60$ m.
For aligning PERI formwork systems and precast concrete elements.

Note

Permissible load see PERI Design Tables.

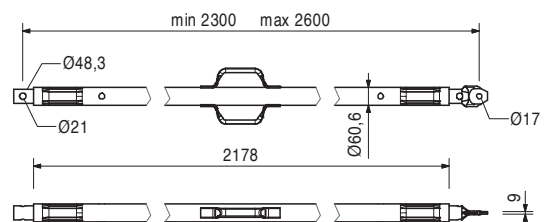
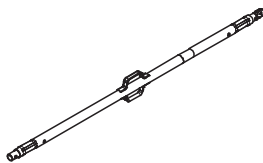

DOMINO 300 Panel Formwork



| Item no. | Weight kg |
|----------|-----------|
| 117467 | 15,500 |

Push-Pull Prop RS 300, galv.
 Extension length L = 1.90 – 3.00 m.
 For aligning PERI formwork systems and precast concrete elements.

Note
 Permissible load see PERI Design Tables.

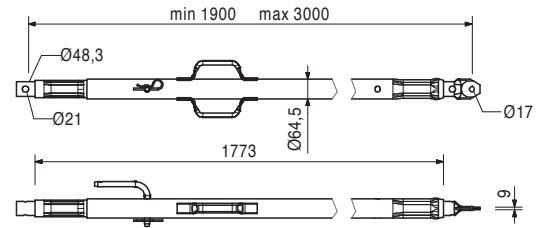
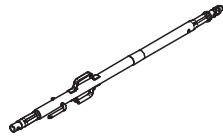

| | |
|--------|--------|
| 117468 | 23,000 |
|--------|--------|

Push-Pull Prop RS 450, galv.
 Extension length L = 2.80 – 4.50 m.
 For aligning PERI formwork systems and precast concrete elements.

Note
 Permissible load see PERI Design Tables.

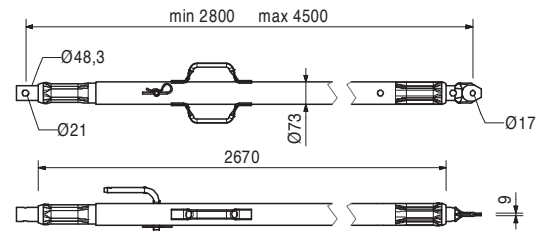
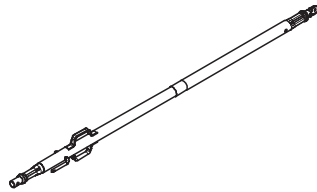

| | |
|--------|--------|
| 117469 | 40,000 |
|--------|--------|

Push-Pull Prop RS 650, galv.
 Extension length L = 4.30 – 6.50 m.
 For aligning PERI formwork systems and precast concrete elements.

Note
 Permissible load see PERI Design Tables.

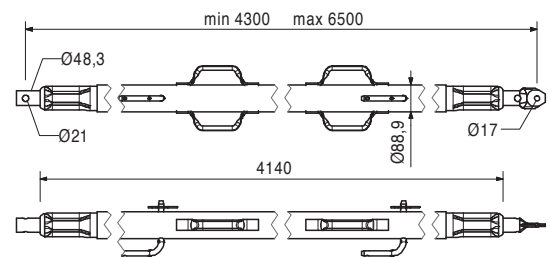
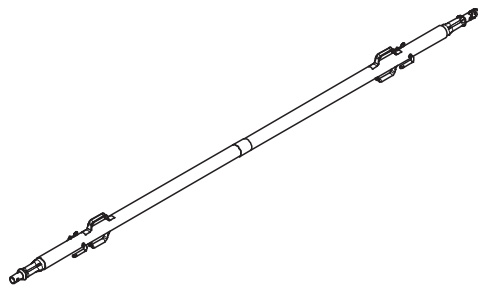

| | |
|--------|---------|
| 028990 | 115,000 |
|--------|---------|

Push-Pull Prop RS 1000, galv.
 Extension length L = 6.40 – 10.00 m.
 For aligning PERI formwork systems.

Note
 Permissible load see PERI Design Tables.

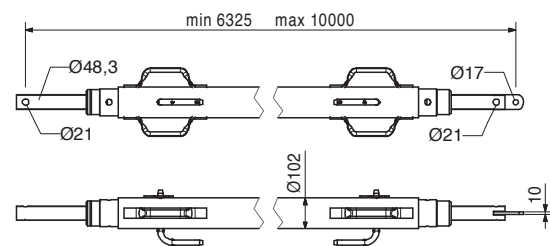
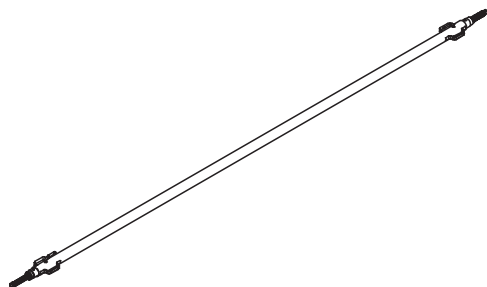

DOMINO 300 Panel Formwork



| Item no. | Weight kg |
|----------|-----------|
| 103800 | 271,000 |

Push-Pull Prop RS 1400, galv.
 Extension length L = 6.40 – 14.00 m.
 For aligning PERI formwork systems.

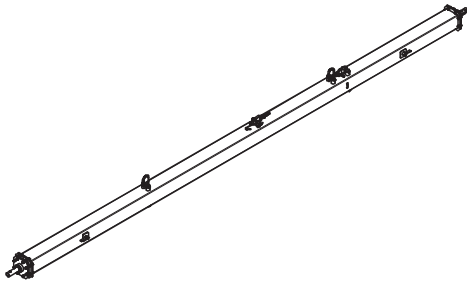

Note
 Permissible load see PERI Design Tables.
 Chain can be operated from bottom.

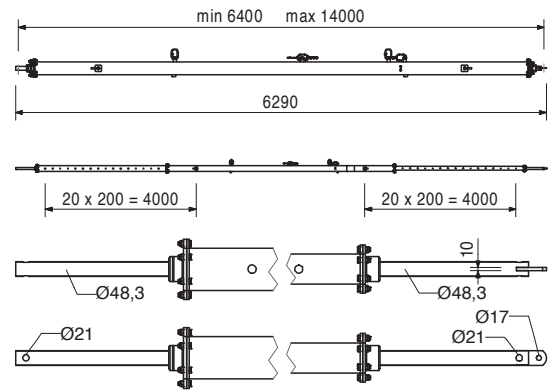

| | |
|--------|-------|
| 117343 | 3,250 |
|--------|-------|

Base Plate-2 for RS 210 – 1400, galv.
 For assembly of Push-Pull Props RS 210, 260, 300, 450, 650, 1000 and 1400.

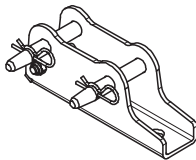

Complete with
 2 pc. 105400 Pin Ø 20 x 140, galv.
 2 pc. 018060 Cotter Pin 4/1, galv.

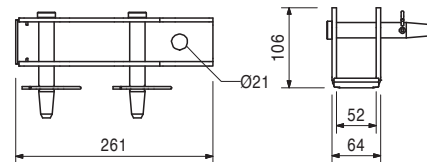

| | |
|--------|-------|
| 124777 | 0,210 |
|--------|-------|

Accessories
Anchor Bolt PERI 14/20 x 130

| | |
|--------|--------|
| 028010 | 17,900 |
|--------|--------|

Push-Pull Prop RSS I
 Extension length L = 2.05 – 2.94 m.
 For aligning PERI formwork systems.

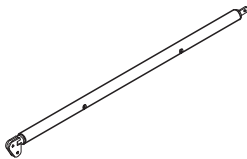

Note
 Permissible load see PERI Design Tables.

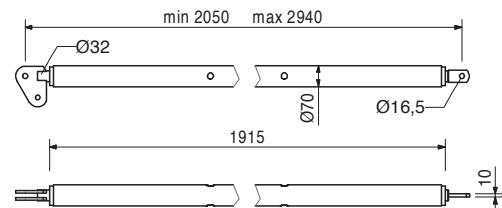

DOMINO 300 Panel Formwork



| Item no. | Weight kg |
|----------|-----------|
| 028020 | 22,000 |

Push-Pull Prop RSS II
 Extension length L = 2.91 – 3.80 m.
 For aligning PERI formwork systems.

Note
 Permissible load see PERI Design Tables.

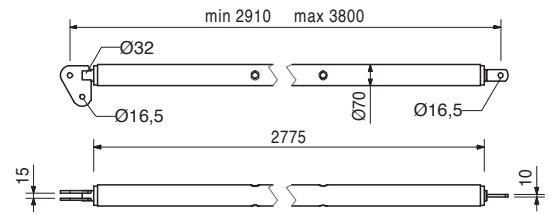
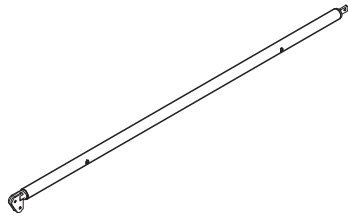

| | |
|--------|--------|
| 028030 | 38,400 |
|--------|--------|

Push-Pull Prop RSS III
 Extension length L = 4.60 – 6.00 m.
 For aligning PERI formwork systems.

Note
 Permissible load see PERI Design Tables.

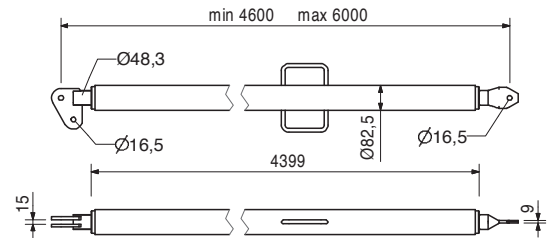
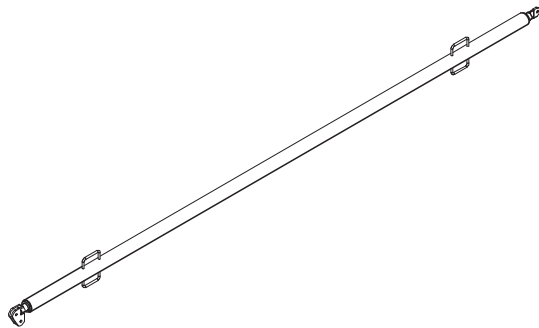

| | |
|--------|-------|
| 106000 | 1,820 |
|--------|-------|

Base Plate-2 for RSS, galv.
 For assembly of RSS Push-Pull Props.

Complete with
 1 pc. 027170 Pin Ø 16 x 42, galv.
 1 pc. 018060 Cotter Pin 4/1, galv.

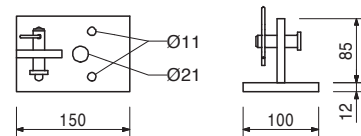
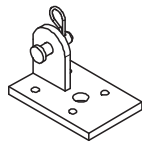

Accessories
Anchor Bolt PERI 14/20 x 130

| | |
|--------|-------|
| 124777 | 0,210 |
|--------|-------|

DOMINO 300 Panel Formwork



| Item no. | Weight kg |
|----------|-----------|
| 057087 | 3,720 |
| 057088 | 4,410 |

Kickers AV
Kicker AV 82
Kicker AV 111
 For aligning PERI formwork systems.

| min. L | max. L |
|--------|--------|
| 500 | 820 |
| 790 | 1110 |

Complete with
 1 pc. 027170 Pin Ø 16 x 42, galv.
 1 pc. 018060 Cotter Pin 4/1, galv.

Note
 Permissible load see PERI Design Tables.

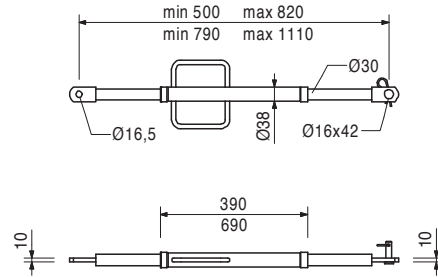
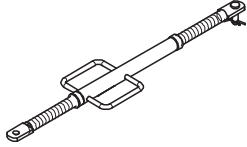

| | |
|--------|-------|
| 028110 | 5,180 |
|--------|-------|

Kicker AV 140
 Extension length L = 1.08 – 1.40 m.
 For aligning PERI formwork systems.

Complete with
 1 pc. 027170 Pin Ø 16 x 42, galv.
 1 pc. 018060 Cotter Pin 4/1, galv.

Note
 Permissible load see PERI Design Tables.

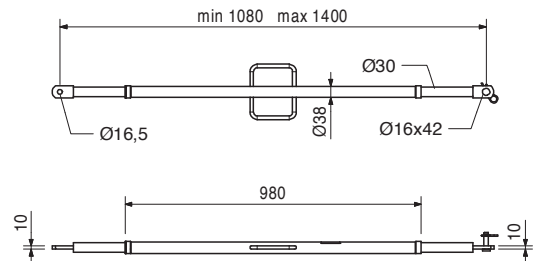
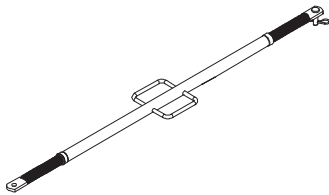

| | |
|--------|--------|
| 108135 | 12,900 |
|--------|--------|

Kicker AV 210
 Extension length L = 1.28 – 2.10 m.
 For aligning PERI formwork systems.

Complete with
 1 pc. 027170 Pin Ø 16 x 42, galv.
 1 pc. 018060 Cotter Pin 4/1, galv.

Note
 Permissible load see PERI Design Tables.

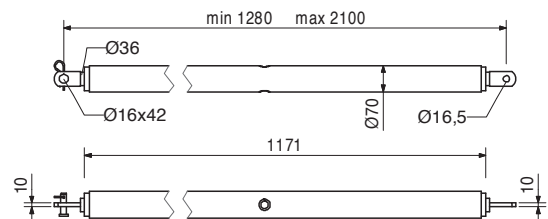
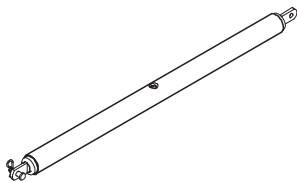

DOMINO 300 Panel Formwork



| Item no. | Weight kg |
|----------|-----------|
| 028120 | 17,000 |

Kicker AV RSS III

Extension length L = 2.03 – 2.92 m.
For aligning PERI formwork systems.

Complete with

1 pc. 027170 Pin \varnothing 16 x 42, galv.
1 pc. 018060 Cotter Pin 4/1, galv.

Note

Permissible load see PERI Design Tables.

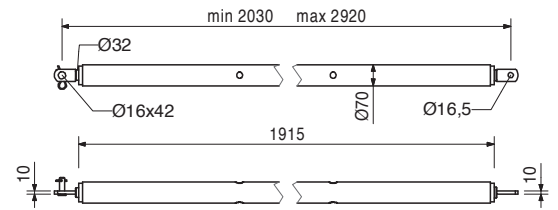
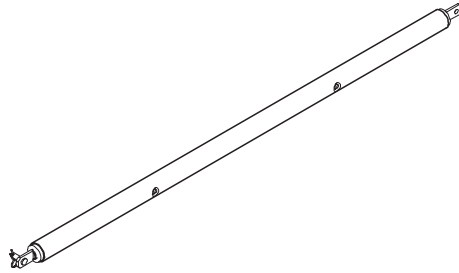

| | |
|--------|-------|
| 124777 | 0,210 |
|--------|-------|

Anchor Bolt PERI 14/20 x 130

For temporary fixation to reinforced concrete structures.

Note

See PERI data sheet!
Drilling \varnothing 14 mm.

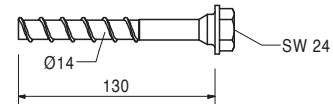
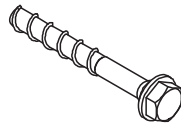

The optimal System for every Project and every Requirement



Wall Formwork



Column Formwork



Slab Formwork



Climbing Systems



Tunnel Formwork



Bridge Formwork



Shoring Systems



Construction Scaffold



Facade Scaffold



Industrial Scaffold



Access



Protection Scaffold



System-Independent Accessories



Services



PERI GmbH
Formwork Scaffolding Engineering
 Rudolf-Diesel-Strasse 19
 89264 Weissenhorn
 Germany
 Tel. +49 (0)7309.950-0
 Fax +49 (0)7309.951-0
 info@peri.com
 www.peri.com